

NOTICE DE MONTAGE/ ASSEMBLY INSTRUCTIONS/
MONTAGEANLEITUNG/ MONTAGE-INSTRUCTIES/ INSTRUCCIONES DE
MONTAJE/ INSTRUÇÕES DE MONTAGEM/ INSTRUZIONI DI MONTAGGIO

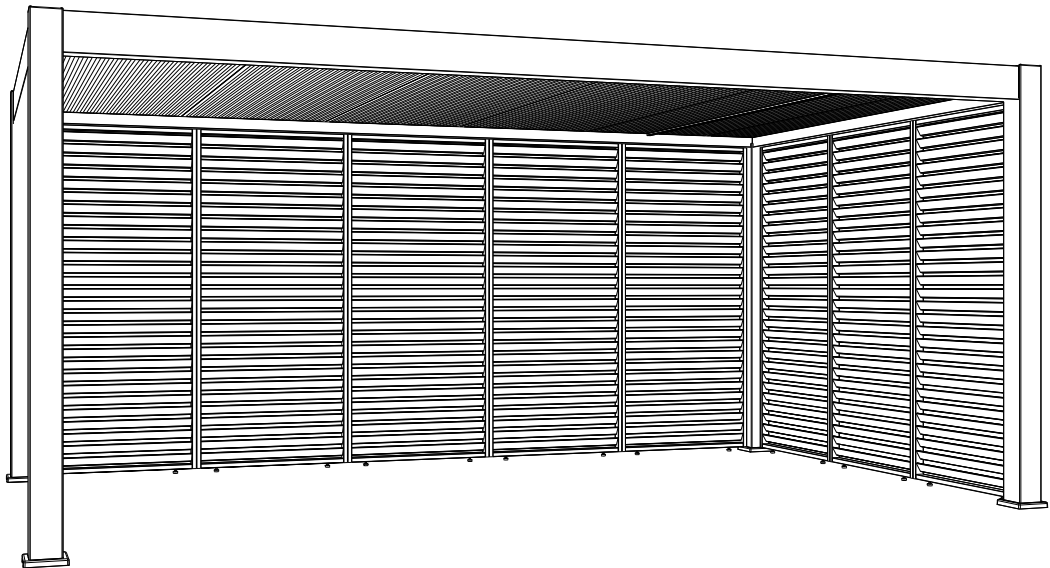

CA0501/CA0502

**MATÉRIEL NÉCESSAIRE POUR L'INSTALLATION / REQUIRED TOOLS FOR INSTALLATION /
 BENÖTIGTES MATERIAL FÜR DIE INSTALLATION / MATERIALEN DIE NODIG ZIJN VOOR DE
 INSTALLATIE / MATERIALES NECESARIOS PARA LA INSTALACION / MATERIAIS NECESSARIOS PARA
 A INSTALAÇÃO / MATERIALI NECESSARI PER L'INSTALLAZIONE**



Lunettes et gants de protection
 Protective glasses and gloves
 Schutzbrille und -handschuhe
 Veiligheidsbril en handschoenen
 Gafas y guantes de protección
 Óculos e luvas de proteção
 Occhiali e guanti di protezione



Escabeau
 Stepladder
 Trittleiter
 Keukentrap
 Escalera de mano
 Escadote
 Scala a pioli

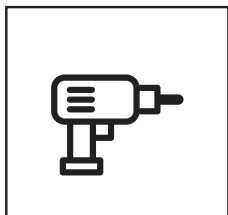

Perceuse-visseuse
 Driller and screwdriver
 Akku-Schlagbohrschrauber
 Schroevendraaier
 Destornillador
 Chave de fendas
 Cacciavite

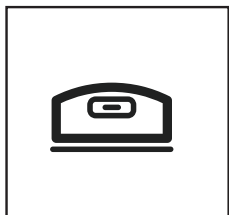

Niveau
 Level
 Wasserwaage
 Waterpas
 Nivel
 Nivel
 Livella

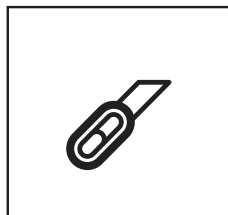

Cutter
 Cutter
 Cutter
 Cortador
 Cortador
 Taglierino



Casque de sécurité
 Safety helmet
 Schutzhelm
 Veiligheidshelm
 Casco de seguridad
 Capacete de segurança
 Casco di sicurezza

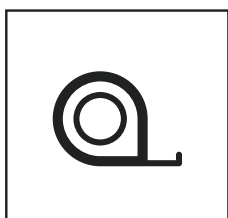

Mètre ruban
 Measuring tape
 Maßband
 Meetlint
 Cinta métrica
 Fita métrica
 Metro a nastro

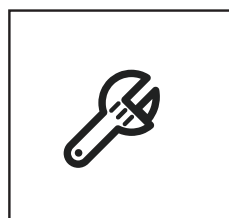

Clé anglaise
 Monkey wrench
 Schraubenschlüssel
 Moersleutel
 Llave inglesa
 Chave inglesa
 Chiave dinamometrica

DIMENSIONS / DIMENSIONS / DIMENSIONEN / AFMETINGEN / DIMENSIONES / DIMENSÕES / DIMENSIONI

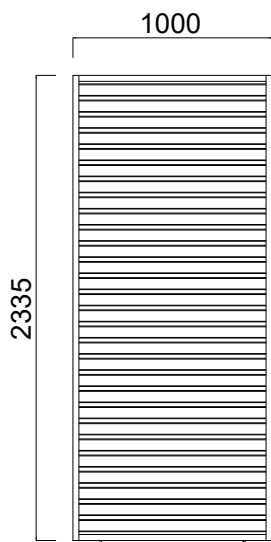



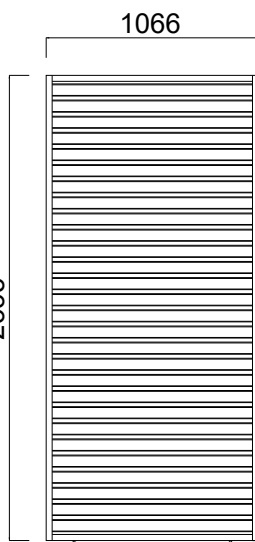







3M

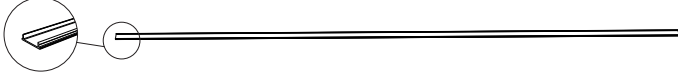

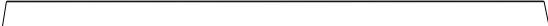

5.3M

CARTON

Reference	Parts	Quantity
M1		1
M2		1
N1		1
N2		1
H1		2
E1	 	1
E2	 	27

Reference	Parts	Quantity
W1	 3.9×25mm	16
W2		2

Reference	Parts	Quantity
W3		2
W5	 PH2	1
W8	 10mm	1

FR	Faire coulisser les pièces H1 des rails M1/M2.
EN	Slide the H1 parts of the M1/M2 rails.
DE	Schieben Sie die H1 -Teile der M1/M2-Schienen zusammen.
NL	Schuif de H1 -delen van de M1/M2-rails.
ES	Deslice las partes H1 de los carriles M1/M2.
PT	Deslizar as partes H1 das calhas M1/M2.
IT	Far scorrere le parti H1 delle guide M1/M2.

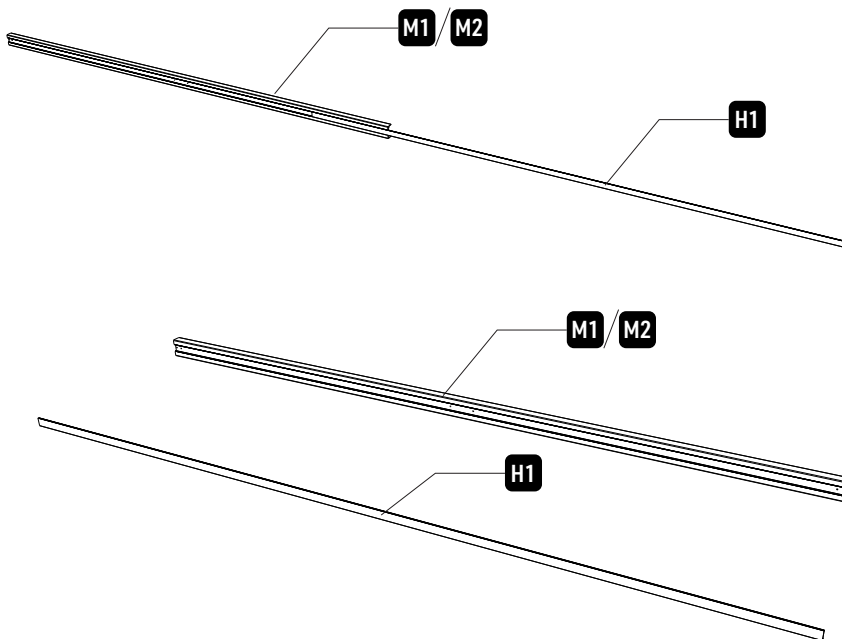

FR	Insérer la pièce E1 (plus longue que les pièces E2) au niveau du trou présent sur les rails M1/M2.
EN	Insert part E1 (longer than parts E2) into the hole in the M1/M2 rails.
DE	Stecken Sie Teil E1 (länger als die Teile E2) in das Loch, das sich in den M1/M2-Schienen befindet.
NL	Steek onderdeel E1 (langer dan onderdelen E2) door het gat in de M1/M2-rails.
ES	Introduzca la pieza E1 (más larga que la pieza E2) a través del orificio de los railes M1/M2.
PT	Introduzir a peça E1 (mais comprida do que a peça E2) através do orifício das calhas M1/M2.
IT	Inserire la parte E1 (più lunga della parte E2) attraverso il foro della guida M1/M2.

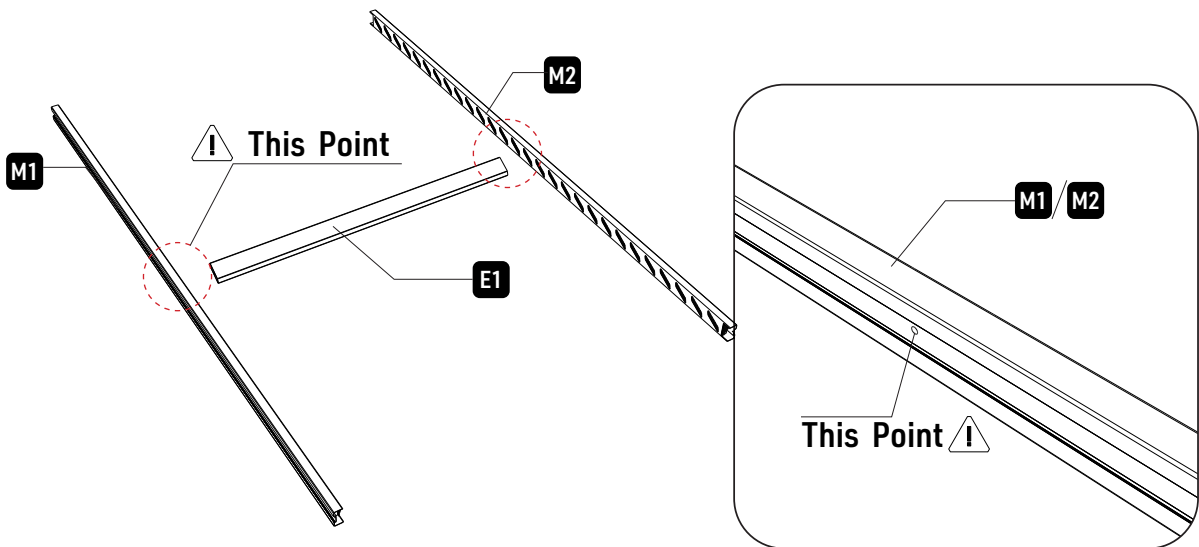

FR	Visser la pièce E1 par l'extérieur à l'aide des vis W1 et de l'embout W4.
EN	Screw on part E1 from the outside, using screws W1 and end cap W4.
DE	Schraube das Teil E1 von außen mit den Schrauben W1 und dem Bit W4 fest.
NL	Schroef deel E1 vanaf de buitenkant vast met schroeven W1 en eindkap W4.
ES	Atornille la pieza E1 desde el exterior con los tornillos W1 y la tapa W4.
PT	Aparafusar a peça E1 a partir do exterior com os parafusos W1 e a tampa W4.
IT	Avvitare la parte E1 dall'esterno con le viti W1 e il tappo di chiusura W4.

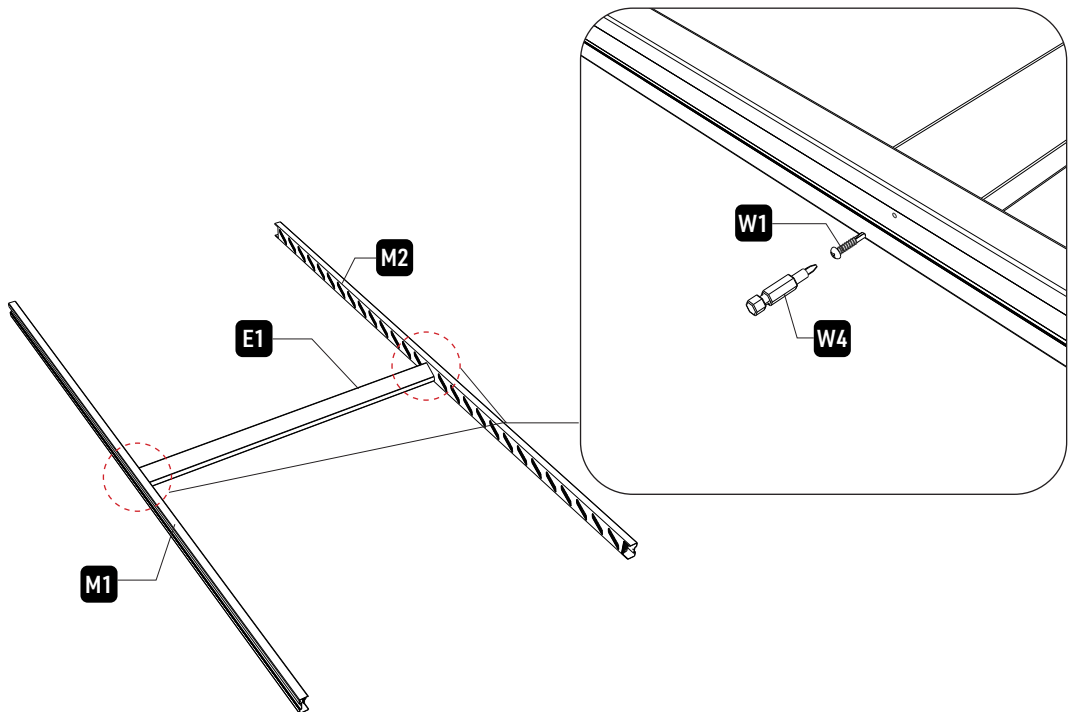

FR	Installer les 2 pièces N1 et N2 aux extrémités supérieures et inférieures. Respecter la numérotation des pièces. Visser avec 2 vis W1 et l'embout W4 en haut et en bas.
EN	Install the 2 parts N1 and N2 at the upper and lower ends. Observe part numbering. Fasten with 2 screws W1 and end cap W4 at top and bottom.
DE	Installiere die 2 Teile N1 und N2 am oberen und unteren Ende. Beachte dabei die Nummerierung der Teile. Schraube mit 2 Schrauben W1 und dem Endstück W4 oben und unten fest.
NL	Installeer de 2 onderdelen N1 en N2 aan de boven- en onderkant. Let op de onderdeelnummers. Bevestig met 2 schroeven W1 en eindkap W4 aan de boven- en onderkant.
ES	Instale las 2 piezas N1 y N2 en los extremos superior e inferior. Observe los números de las piezas. Sujete con 2 tornillos W1 y la tapa de extremo W4 en la parte superior e inferior.
PT	Instalar as 2 peças N1 e N2 nas extremidades superior e inferior. Observar os números das peças. Fixar com 2 parafusos W1 e tampa de extremidade W4 em cima e em baixo.
IT	Installare le 2 parti N1 e N2 alle estremità superiore e inferiore. Osservare i numeri di parte. Fissare con 2 viti W1 e il tappo di chiusura W4 in alto e in basso.

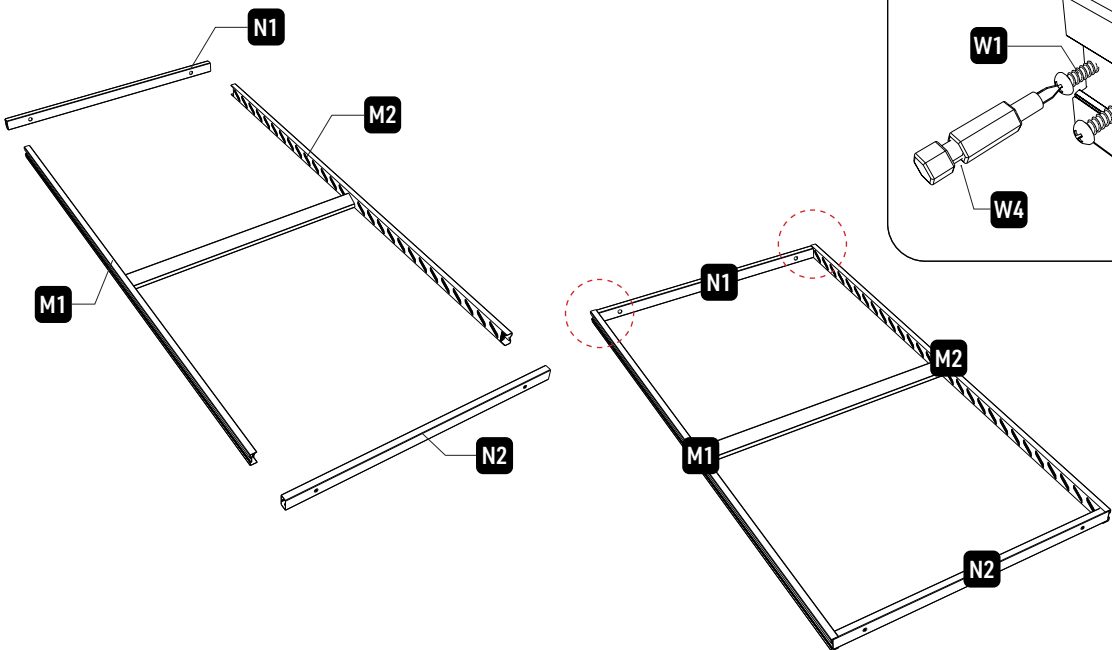

FR	Visser les pieds réglables W2 sur la partie inférieure du cadre N2. Ne pas serrer trop fort.
EN	Screw the W2 adjustable feet onto the bottom of the N2 frame. Do not overtighten.
DE	Schrauben Sie die verstellbaren Füße W2 an die Unterseite des Rahmens N2. Nicht zu fest anziehen.
NL	Schroef de stelvoetjes W2 aan de onderkant van het frame N2. Niet te vast aandraaien.
ES	Atornille los pies regulables W2 a la parte inferior del bastidor N2. No apriete demasiado.
PT	Aparafusar os pés reguláveis W2 à parte inferior do quadro N2. Não apertar demasiado.
IT	Avvitare i piedini regolabili W2 alla parte inferiore del telaio N2. Non serrare eccessivamente.

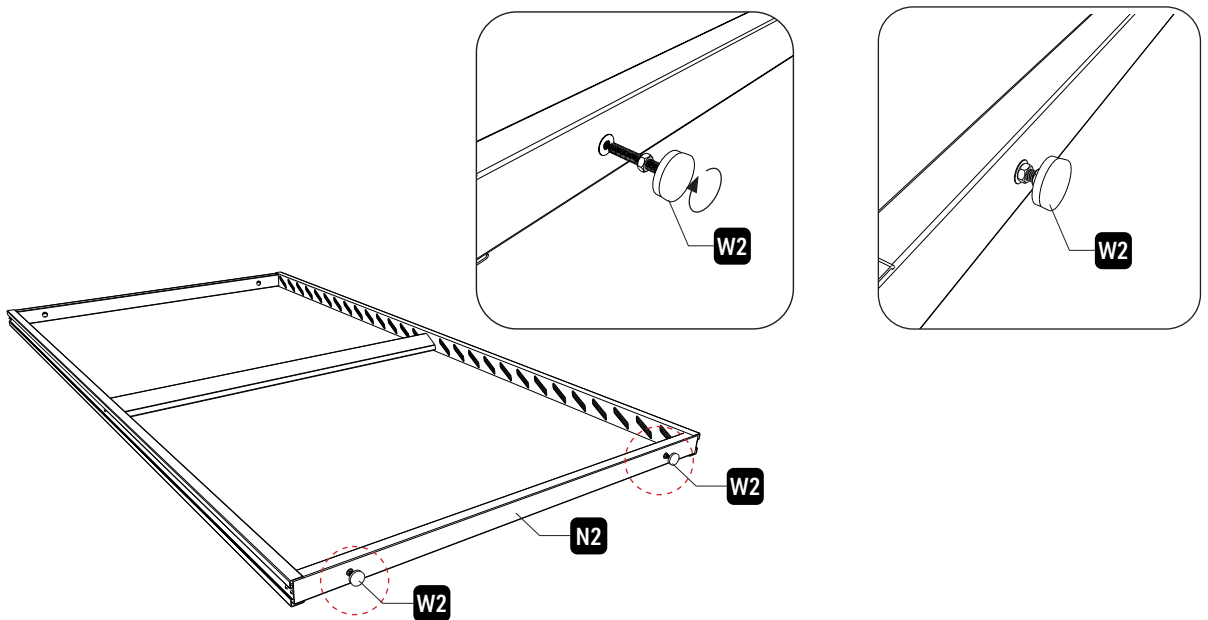

FR	Faire coulisser les pièces H1 sur chaque côté du cadre M1/M2, comme sur l'image.
EN	Slide the H1 parts onto each side of the M1/M2 frame, as shown.
DE	Schieben Sie die H1-Teile auf jede Seite des M1/M2-Rahmens, wie in der Abbildung gezeigt.
NL	Schuif de H1-onderdelen aan weerszijden van het M1/M2-frame, zoals weergegeven in de afbeelding.
ES	Deslice las piezas H1 a cada lado del marco M1/M2, como se muestra en la imagen.
PT	Deslize as peças H1 para cada lado da estrutura M1/M2, como mostra a figura.
IT	Far scorrere le parti H1 su ciascun lato del telaio M1/M2, come mostrato nella figura..

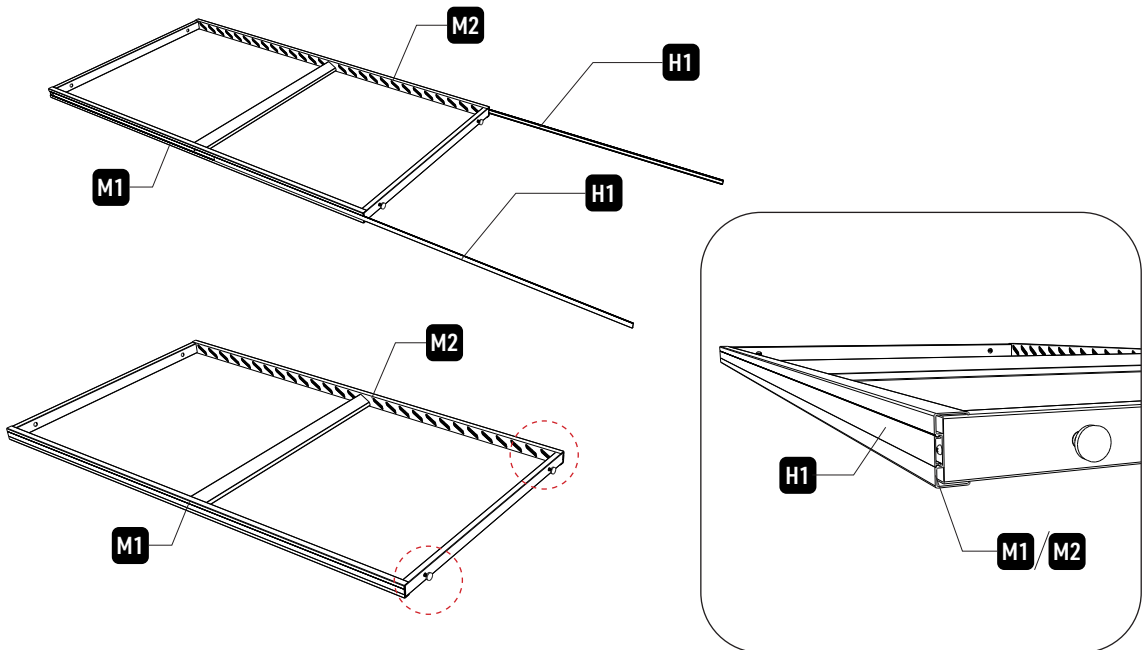

FR	Installer le cadre sur la pergola contre l'un des poteaux. Attention il doit être aligné avec la poutre supérieure.
EN	Install the frame on the pergola against one of the posts. It must be aligned with the top beam.
DE	Bringen Sie den Rahmen an der Pergola an einem der Pfosten an. Achten Sie darauf, dass er mit dem oberen Balken fluchtet.
NL	Installeer het frame op de pergola tegen een van de palen. Zorg ervoor dat het uitgelijnd is met de bovenste balk.
ES	Instale el marco de la pérgola contra uno de los postes. Asegúrese de que esté alineado con la viga superior.
PT	Instale a estrutura na pérgola contra um dos postes. Certifique-se de que está alinhada com a viga superior.
IT	Installare il telaio della pergola contro uno dei pali. Assicuratevi che sia allineato con la trave superiore.

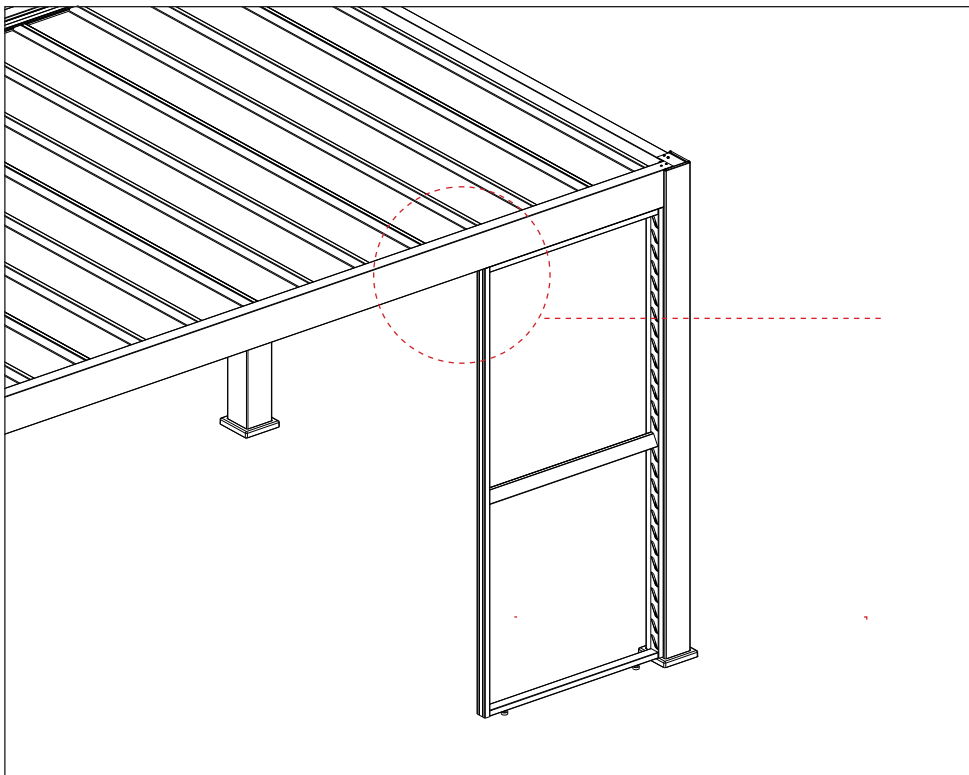

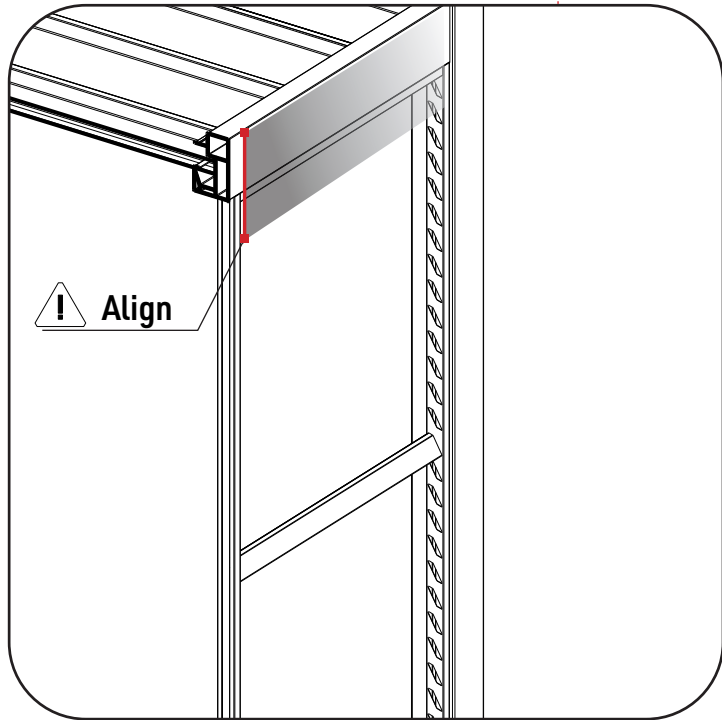

FR	Ajuster la hauteur des pieds en dévissant.
EN	Adjust height of feet by unscrewing.
DE	Passen Sie die Höhe der Füße durch Abschrauben an.
NL	Pas de hoogte van de poten aan door ze los te draaien.
ES	Ajuste la altura de los pies desenroscando.
PT	Ajustar a altura dos pés desaparafusando-os.
IT	Regolare l'altezza dei piedini svitandoli.

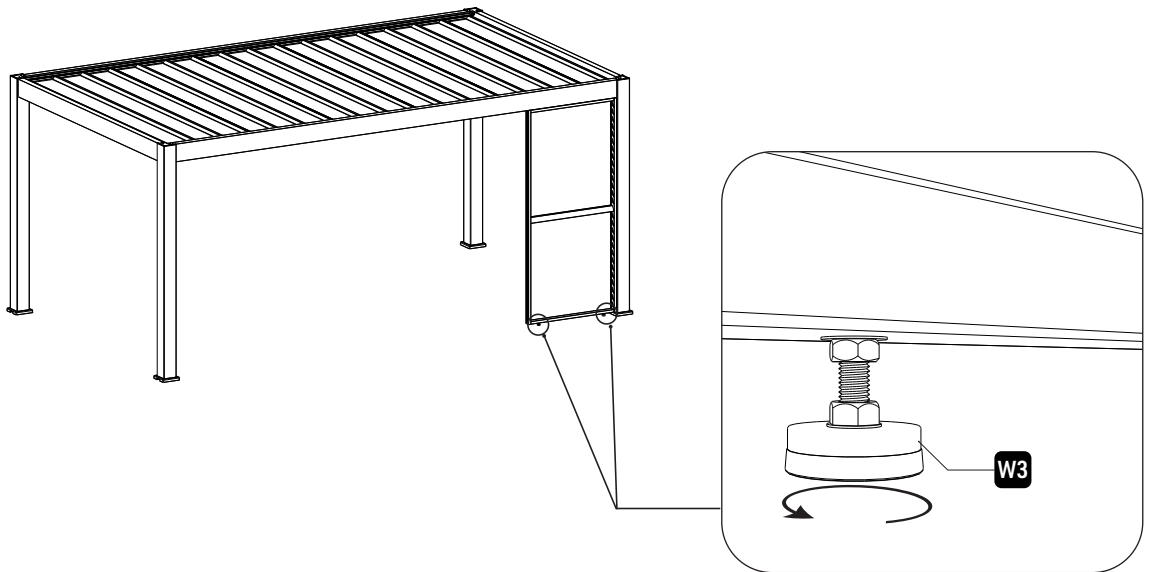

FR	Fixer le cadre sur le poteau à l'aide de 2 vis W1 et de l'embout W4, comme sur l'image.
EN	Fix the frame to the post using 2 W1 screws and W4 end cap, as shown in the picture.
DE	Befestigen Sie den Rahmen mit 2 Schrauben W1 und der Endkappe W4 am Pfosten, wie auf dem Bild gezeigt.
NL	Bevestig het frame aan de paal met 2 W1 schroeven en de W4 eindkap, zoals te zien is op de afbeelding.
ES	Fije el marco al poste con 2 tornillos W1 y la tapa W4, como se muestra en la imagen.
PT	Fixe a estrutura ao poste com 2 parafusos W1 e a tampa W4, como mostra a figura.
IT	Fissare il telaio al palo con 2 viti W1 e il tappo terminale W4, come mostrato nella figura.

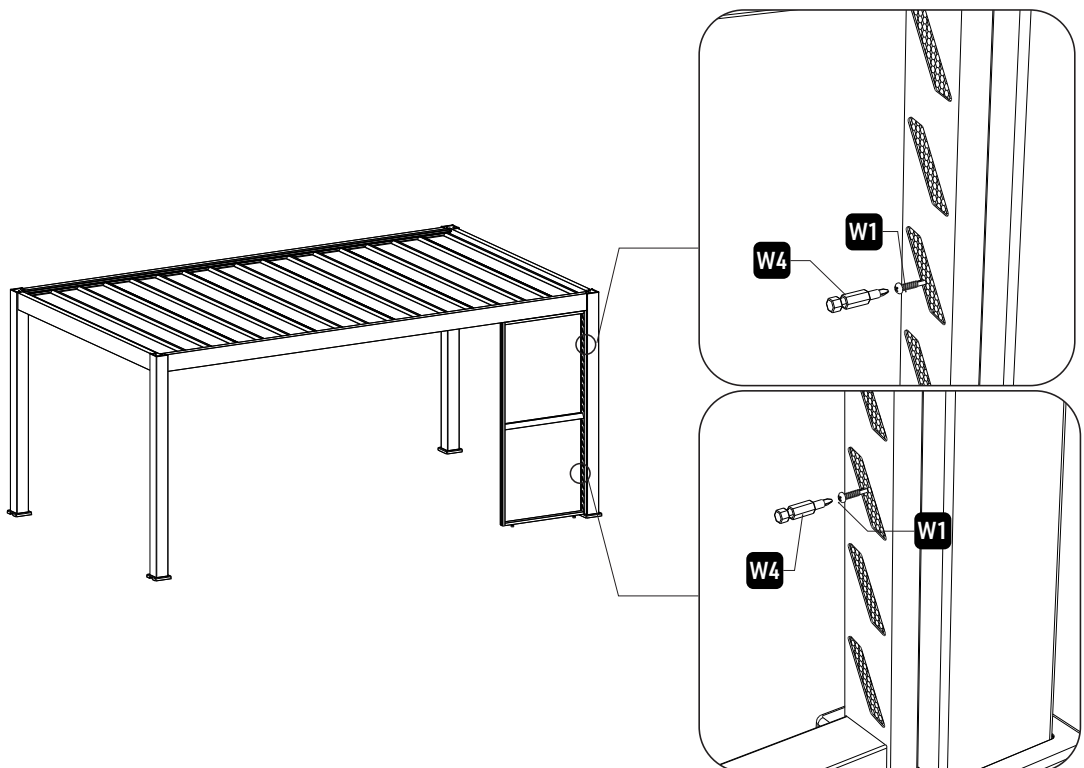

FR	Fixer le cadre sur la poutre à l'aide de 2 vis W1 puis ajouter les caches W3.
EN	Fix the frame to the beam using 2 W1 screws, then add the W3 covers.
DE	Befestige den Rahmen mit 2 Schrauben W1 am Balken und füge dann die Abdeckungen W3 hinzu.
NL	Bevestig het frame aan de balk met 2 W1-schroeven en breng vervolgens de W3-deksels aan.
ES	Fije el marco a la viga con 2 tornillos W1 y, a continuación, añade las tapas W3.
PT	Fixar a estrutura à viga com 2 parafusos W1 e, em seguida, colocar as tampas W3.
IT	Fissare il telaio alla trave con 2 viti W1, quindi aggiungere le coperture W3.

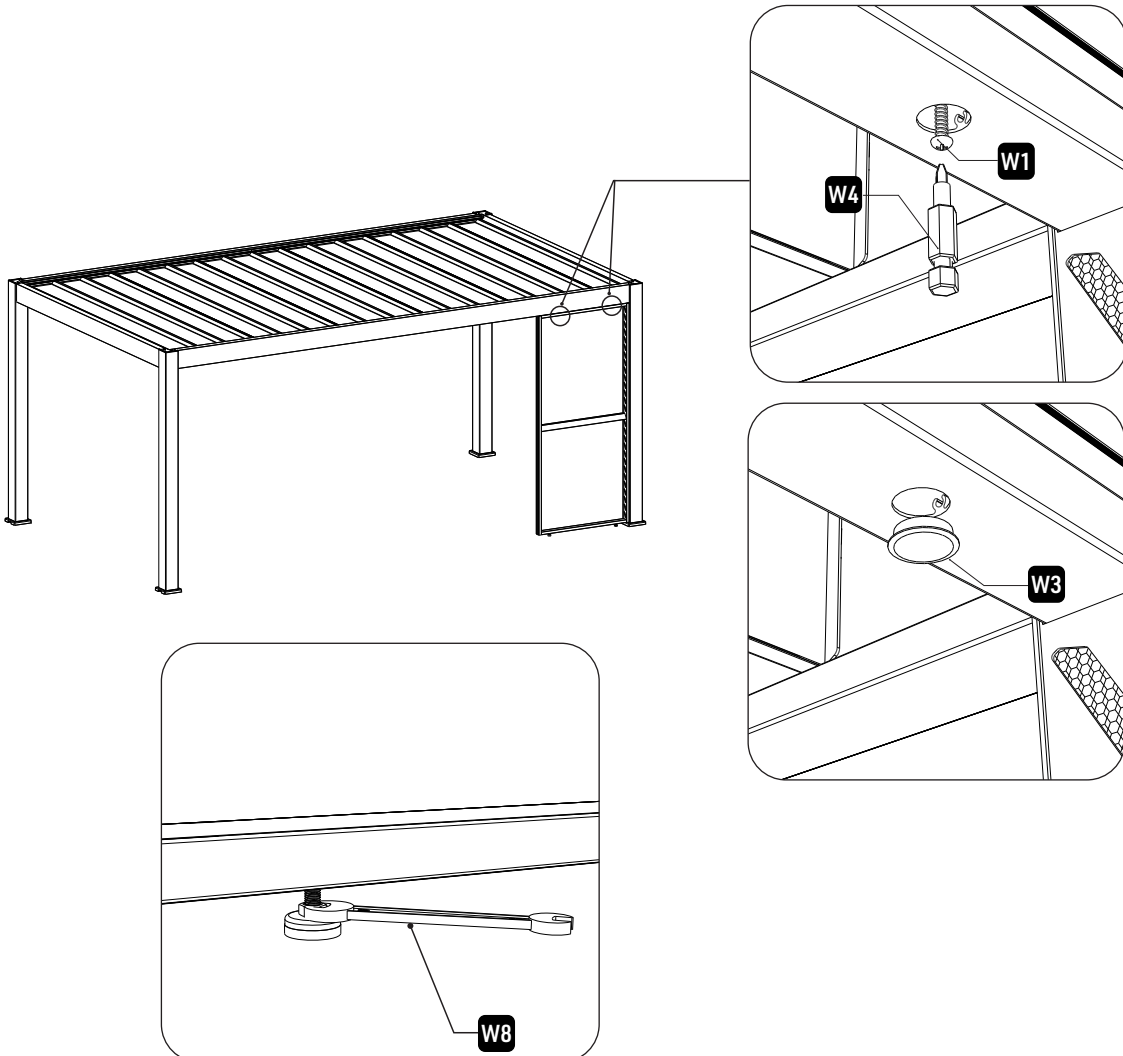

FR	Ajouter le reste des lames E2 sur le cadre, en pressant d'un côté pour faire rentrer l'autre extrémité dans l'encoche. Attention au sens des lames.
EN	Add the remaining E2 slats to the frame, pressing one end into the notch. Pay attention to the direction of the blades.
DE	Füge die restlichen E2-Lamellen auf den Rahmen, indem du auf einer Seite drückst, damit das andere Ende in die Kerbe passt. Achte auf die Ausrichtung der Lamellen.
NL	Voeg de rest van de E2-lamellen toe aan het frame en druk de ene kant naar beneden om het andere uiteinde in de inkeping te plaatsen. Let op de richting van de latten.
ES	Añada el resto de las lamas E2 al marco, presionando un lado para encajar el otro extremo en la muesca. Preste atención a la dirección de las lamas.
PT	Adicione o resto das ripas E2 à estrutura, pressionando num dos lados para encaixar a outra extremidade no entalhe. Preste atenção à direção das ripas.
IT	Aggiungere il resto delle lamelle E2 al telaio, premendo su un lato per inserire l'altra estremità nella tacca. Prestare attenzione alla direzione delle lamelle.

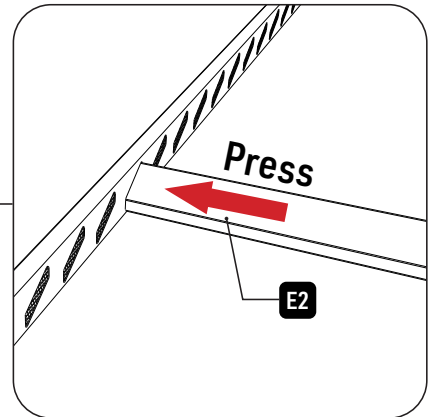
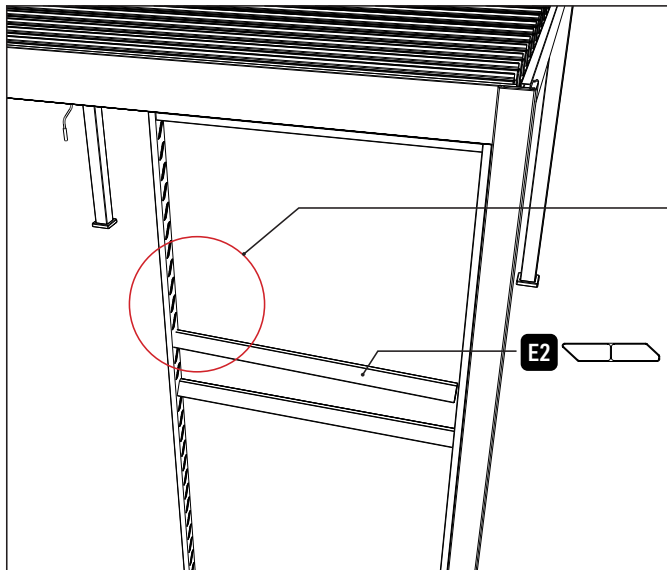

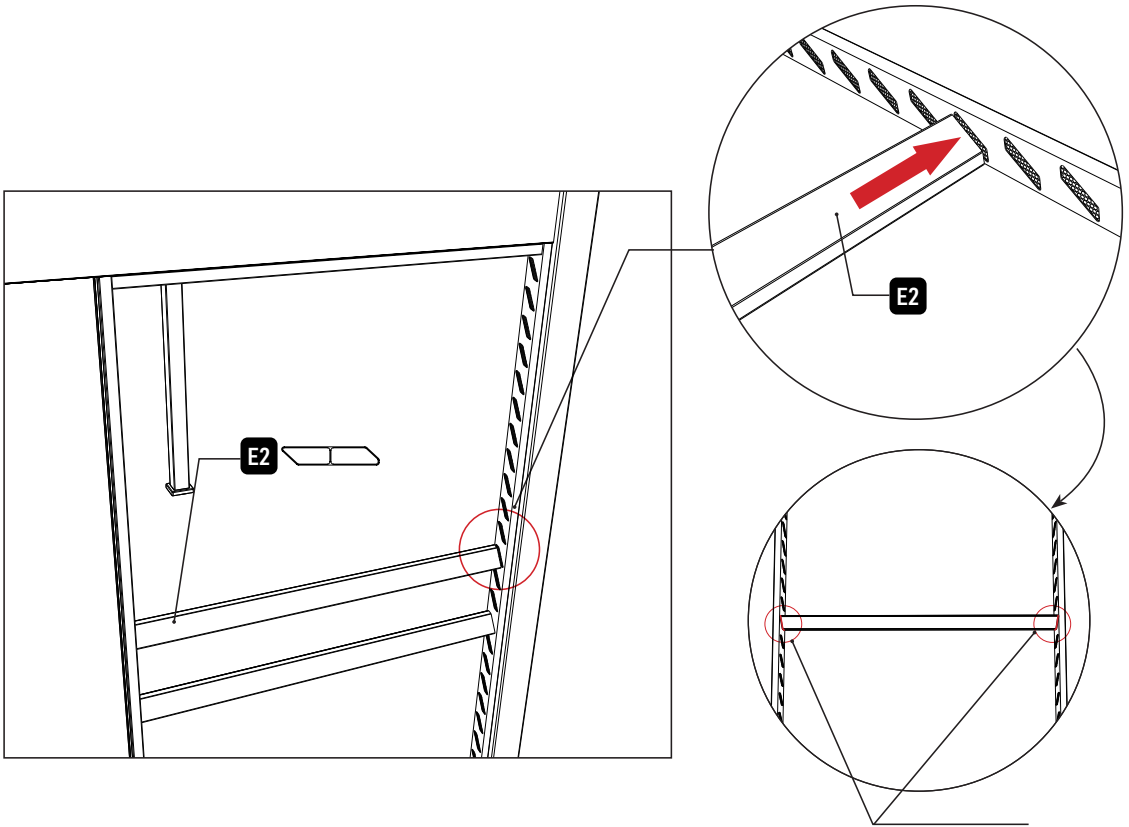

+1

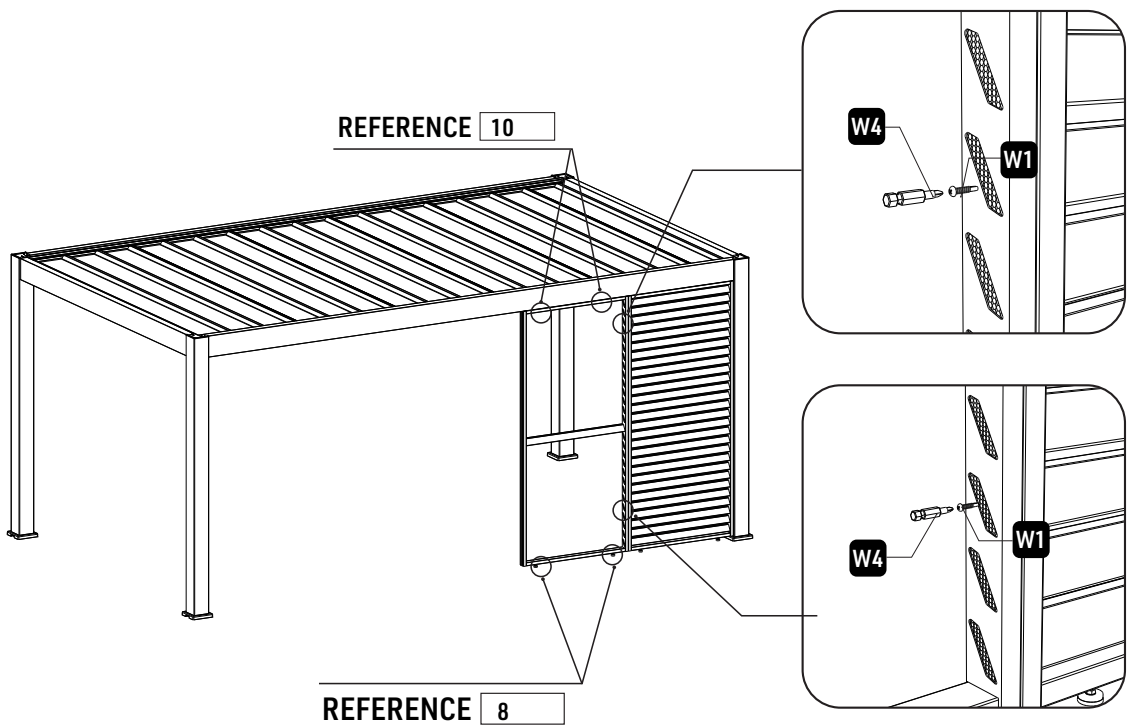
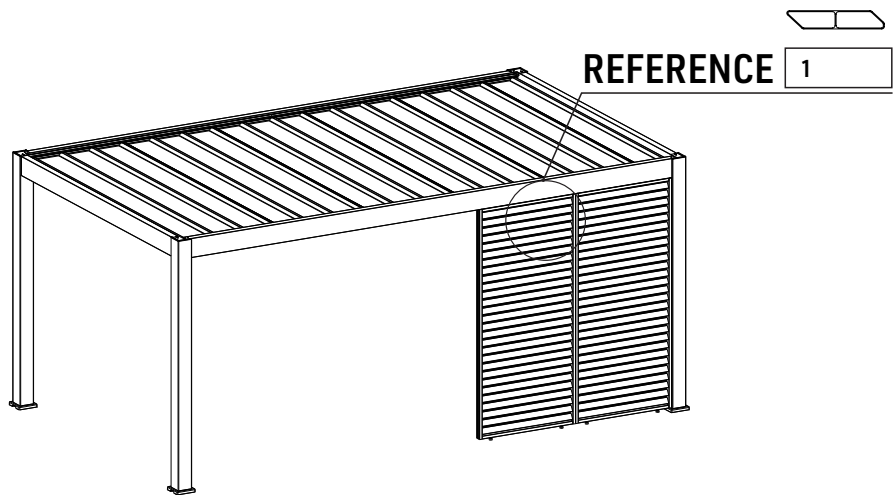



When installing three privacy panels, please repeat the same installation steps as above.

Just remember when there is any connection, you always need to fix the privacy panel frame according to step 9.

FR	Pour l'ajout d'un 3e panneau, répéter l'opération puis fixer le panneau sur le poteau comme dans l'étape 9. Pour l'ajout de 4 et 5 panneaux, ne pas oublier de fixer les panneaux entre eux comme sur l'étape précédente
EN	To add a 3rd panel, repeat the operation and attach the panel to the post as in step 9. To add 4 and 5 panels, don't forget to fasten the panels together as in the previous step.
DE	Um eindrittes Paneel hinzuzufügen, wiederholen Sie den Vorgang und befestigen Sie das Paneel dann wie in Schritt 9 am Pfosten. Wenn Sie 4 oder 5 Paneele hinzufügen, vergessen Sie nicht, die Paneele wie im vorherigen Schritt aneinander zu befestigen.
NL	Om een 3e paneel toe te voegen, herhaalt je de handeling en bevestig je het paneel aan de paal zoals in stap 9. Om 4 en 5 panelen toe te voegen, vergeet niet de panelen aan elkaar te bevestigen zoals in de vorige stap.
ES	Para añadir un 3er panel, repita la operación y fije el panel al poste como en el paso 9. Para añadir 4 y 5 paneles, no olvide fijar los paneles juntos como en el paso anterior.
PT	Adicione o resto das ripas E2 à estrutura, pressionando num dos lados para encaixar a outra extremidade no entalhe. Preste atenção à direção das ripas.
IT	Per aggiungere un terzo pannello, ripetere l'operazione e fissare il pannello al palo come al punto 9. Per aggiungere 4 e 5 pannelli, non dimenticate di fissarli insieme come nel passaggio precedente.

