

ELIOS

perenza

NOTICE DE MONTAGE / ASSEMBLY INSTRUCTIONS / MONTAGEANLEITUNG /
MONTAGE-INSTRUCTIES / INSTRUCCIONES DE MONTAJE / INSTRUÇÕES DE
MONTAGEM / INSTRUZIONI DI MONTAGGIO

5300 x 3600 mm

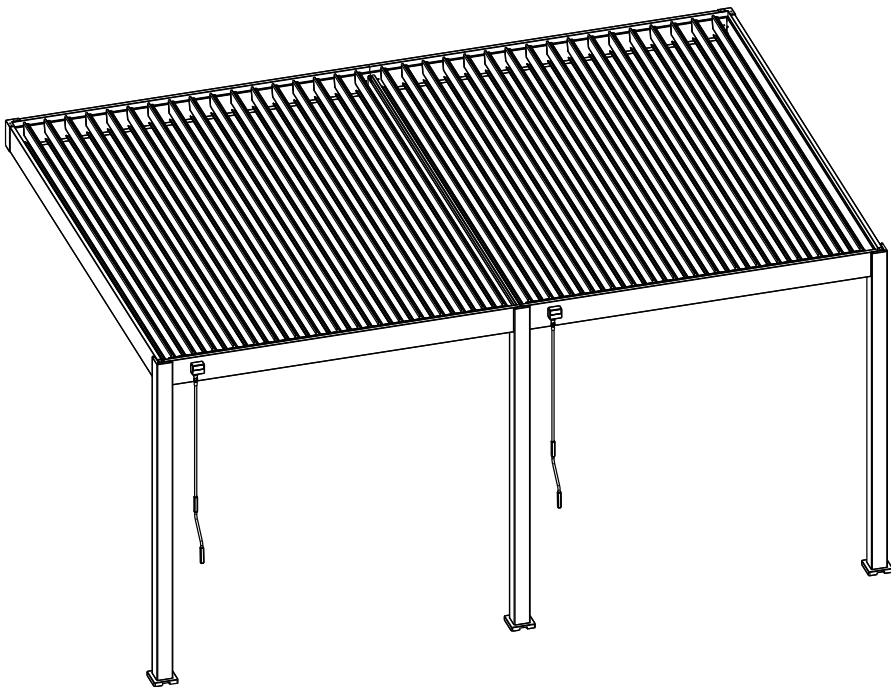

PE1171 PE1176

FR - RECOMMANDATIONS

Notice à conserver pendant toute la durée de vie du produit.

Selon l'emplacement et la surface, l'installation d'une pergola peut être soumise à une déclaration préalable de travaux ou une demande de permis de construire. Vérifier la réglementation en vigueur avant l'installation. Lire attentivement la notice avant de procéder au montage, s'assurer qu'aucune pièce n'est endommagée ou manquante. La pergola doit être installée dans un environnement adapté, sur une fondation stable et nivelée, telle une dalle béton ou des plots béton de 50 x 50 x (P)60 cm au niveau de chaque poteau. Veiller à ancrer la pergola au sol à l'aide des chevilles de fixation fournies. Le montage de ce produit nécessite au moins deux personnes. Assembler toutes les pièces en suivant les instructions de ce manuel et ne sauter aucune étape. Traiter les pièces avec un soin extrême avant et pendant le montage et les poser avec précaution sur le sol, éviter de marcher dessus ou d'y placer des objets. Il est recommandé d'installer la pergola par temps sec. En cas de non-respect des recommandations de montage, la garantie ne pourra être appliquée.

CONSEILS D'UTILISATION

En cas de fortes intempéries et de chute de neige, ouvrir les lames à la verticale pour protéger la pergola. Cette pergola peut supporter de fortes pluies, mais nous ne pouvons garantir une étanchéité à 100%. Ne pas monter sur le toit de la pergola. Aucune modification ne peut être apportée au produit. Les produits modifiés par l'utilisateur ne seront pas couverts par la garantie. En cas de mauvaise utilisation du produit, nous ne pourrions être tenus responsables des dommages ou blessures causés.

GARANTIE DU PRODUIT

La garantie ne pourra s'appliquer qu'en cas de respect des conseils de montage, d'utilisation et d'entretien. La garantie ne couvre pas :

- L'usure normale du produit
- La perte ou la casse de toute pièce lors du déballage et/ou de l'installation
- Le vandalisme
- Les conditions climatiques extrêmes : vents forts, tempêtes, grêle, neige, inondations, foudre...

ENTRETIEN DU PRODUIT

Un entretien régulier du produit est recommandé pour assurer sa longévité.

- Laver la pergola 1 à 2 fois par an à l'eau douce à l'aide d'une éponge ou d'un chiffon. Ne pas utiliser un produit agressif ou un support abrasif.
- Vérifier le serrage des vis régulièrement (au moins 1 fois par an).
- Huiler les pièces de quincaillerie régulièrement (au moins 1 fois par an).
- Veiller à ce que rien ne gêne l'écoulement des eaux dans les gouttières (feuilles, branches...).
- Enlever l'eau qui pourrait stagner autour des pieds de la pergola (soulever les protections).

EN – RECOMMENDATIONS

This installation guide must be kept during the product lifetime. The construction of this pergola may be subject to a building permit, it depends on the location and the surface area. Please check the local regulation before installation. Read carefully the instructions before proceeding to the installation, make sure any component is neither missing nor damaged. The pergola must be installed in a suitable environment, on a stable and level ground, such as a concrete slab or concrete pads of 50 x 50 x (D)60 cm at each post. Make sure to anchor the pergola to the ground using the fixing plugs provided. The installation of this product must be done with 2 people at least. Follow the instructions to assembly all the parts, without skipping any step. Be careful with all the pieces before and during the installation, lay them carefully on the floor, avoid stepping on them or placing any object on them. We recommend installing the pergola in dry weather. The product warranty cannot be applied in case of non-compliance with the installation recommendations.

PRECAUTION FOR USE

We highly recommend opening the louvers in case of strong wind or snow. This pergola withstands heavy rain but we cannot guarantee it will 100% waterproof. Do not climb on the roof. No change can be made to the product. In case of any change, the product warranty is no longer valid. In case of misuse of the product, we cannot be held responsible for any damage or injury caused.

PRODUCT WARRANTY

The warranty can only apply whether the installation, use and maintenance are observed. The warranty does not cover :

- Normal wear of the product
- Loss or breakage of any part during unpacking and/or installation
- Vandalism
- Extreme weather conditions: strong winds, storms, hail, snow, floods, lightning...

PRODUCT MAINTENANCE

Regular maintenance of the product is recommended to maximize the product lifetime.

- Wash the product once or twice a year with water and a soft cloth. Do not use aggressive product or abrasive support.
- Check the tightness of the screws (at least once a year).
- Oil the hardware parts regularly (at least once a year).
- Make sure the flow of water in the gutters is not obstructed by any leaf, branch...
- Remove the stagnate water around the feet of the pergola.

DE - EMPFEHLUNGEN

Diese Anleitung sollte während der gesamten Lebensdauer des Produkts aufbewahrt werden. Je nach Standort und Fläche kann für die Installation einer Pergola eine vorherige Bauanmeldung oder ein Antrag auf Baugenehmigung erforderlich sein. Überprüfen Sie vor der Einrichtung die geltenden Vorschriften. Lesen Sie die Anleitung vor der Montage aufmerksam durch und vergewissern Sie sich, dass keine Teile beschädigt sind oder fehlen. Die Pergola muss in einer geeigneten Umgebung auf einem stabilen und ebenen Untergrund wie einer Betonplatte oder Betonklötzen mit den Maßen 50 x 50 x (T)60 cm an jedem Pfosten aufgestellt werden. Achten Sie darauf, dass die Pergola mit den mitgelieferten Dübeln im Boden verankert wird. Um dieses Produkt aufzubauen, sind mindestens zwei Personen erforderlich. Bauen Sie alle Teile gemäß den Anweisungen in dieser Anleitung zusammen und lassen Sie keinen Schritt aus. Behandeln Sie die Bauteile mit äußerster Sorgfalt vor und während der Montage und legen Sie sie vorsichtig auf den Boden. Vermeiden Sie es, darauf zu treten oder Gegenstände darauf abzustellen. Es wird empfohlen, die Pergola bei trockenem Wetter aufzubauen. Bei Nichteinhaltung der Montageempfehlungen, kann die Garantie nicht in Anspruch genommen werden.

NUTZUNGSHINWEISE

Bei starkem Unwetter und Schneefall sollten Sie die Lamellen senkrecht öffnen, um die Pergola zu schützen. Diese Pergola kann starken Regenfällen ausgesetzt werden, aber wir können keine 100%ige Wasserdichtigkeit garantieren. Steigen Sie nicht auf das Dach der Pergola. Es dürfen keine Veränderungen am Produkt vorgenommen werden. Produkte, die vom Nutzer verändert wurden, fallen nicht unter die Garantie. Bei unsachgemäßer Verwendung des Produktes können wir nicht für Schäden oder Verletzungen haftbar gemacht werden.

PRODUKTGARANTIE

Die Garantie kann nur dann in Anspruch genommen werden, wenn die Montage-, Gebrauchs- und Pflegehinweise beachtet werden. Die Garantie deckt nicht ab:

- Den normalen Verschleiß des Produkts.
- Den Verlust oder Bruch von Bauteilen während des Auspackens und/oder dem Aufbau.
- Vandalismus
- Extreme Wetterbedingungen: starke Winde, Stürme, Hagel, Schnee, Überschwemmungen, Blitzschlag...

PRODUKTPFLEGE

Eine regelmäßige Pflege des Produkts wird empfohlen, um seine Langlebigkeit zu gewährleisten.

- Waschen Sie die Pergola ein- bis zweimal pro Jahr mit Süßwasser und einem Schwamm oder Tuch. Verwenden Sie keine scheuernden oder aggressiven Reinigungsmittel.
- Überprüfen Sie regelmäßig (mindestens 1-mal pro Jahr), ob die Schrauben festsitzen.
- Ölen Sie die Beschläge regelmäßig (mindestens 1-mal pro Jahr).
- Achten Sie darauf, dass nichts den Wasserabfluss in den Regenrinnen behindert (Blätter, Äste...).
- Entfernen Sie Wasser, das um die Füße der Pergola stehen bleiben könnte (heben Sie die Schutzvorrichtungen an).

NL - AANBEVELINGEN

Bewaar deze instructies tijdens de gehele levensduur van het product. Afhankelijk van de locatie en de oppervlakte kan de installatie van een pergola onderworpen zijn aan een meldingsplicht of de aanvraag van een bouwvergunning. Controleer vóór de installatie de geldende voorschriften in uw regio. Lees aandachtig de instructies alvorens de pergola te installeren en controleer of er geen onderdelen beschadigd zijn of ontbreken. De pergola moet worden geïnstalleerd in een geschikte omgeving, op een stabiele, vlakke ondergrond, zoals een betonnen plaat of betonblokken van 50 x 50 x (D)60 cm bij elke paal. Veranker de pergola in de grond met de meegeleverde bevestigingspluggen. Er zijn minstens twee personen nodig om dit product te monteren. Monteer alle onderdelen volgens de instructies in deze handleiding en sla geen stappen over. Behandel de onderdelen met uiterste zorg vóór en tijdens de montage en leg ze voorzichtig op de grond, stap er niet op en plaats er geen voorwerpen op. Wij raden aan de pergola bij droog weer te installeren. Als de montage-instructies niet nageleefd zijn, vervalt de garantie.

AANBEVELINGEN VOOR GEBRUIK

Bij zwaar weer of sneeuwval de lamellen verticaal openen om de pergola te beschermen. Deze pergola is bestand tegen zware regenval, maar wij kunnen geen 100% waterdichtheid garanderen. Klim niet op het dak van de pergola. Aan het product mogen geen wijzigingen worden aangebracht. Door de gebruiker gewijzigde producten vallen niet meer onder de garantie. Bij verkeerd gebruik van het product kunnen wij niet aansprakelijk worden gesteld voor eventuele schade of letsel.

PRODUCTGARANTIE

De garantie geldt alleen als de montage-, gebruiks- en onderhoudsvoorschriften zijn opgevolgd. De garantie dekt niet :

- Normale slijtage
- Verlies of breuk van een onderdeel tijdens het uitpakken en/of installeren
- Vandalisme
- Extreme weersomstandigheden: harde wind, storm, hagel, sneeuw, overstroming, bliksem, enz.

ONDERHOUD VAN HET PRODUCT

Regelmatig onderhoud van het product is nodig om de levensduur te garanderen.

- Was de pergola één of twee keer per jaar met schoon water met een spons of doek. Gebruik geen agressieve of schurende middelen.
- Controleer regelmatig (minstens één keer per jaar) of de schroeven goed vastzitten.
- Smeer de metalen onderdelen regelmatig (minstens één keer per jaar).
- Zorg ervoor dat niets de waterafloop in de goten belemmert (bladeren, takken, enz.).
- Verwijder eventueel stilstaand water rond de poten van de pergola (til de deksels op).

ES – RECOMENDACIONES

Conserve estas instrucciones durante toda la vida útil del producto. Dependiendo de la ubicación y de la superficie, la instalación de una pérgola puede estar sujeta a una declaración previa de obras o a una solicitud de licencia urbanística. Compruebe la normativa vigente antes de la instalación. Lea atentamente las instrucciones antes de instalar la pérgola y compruebe que no falte ninguna pieza ni esté dañada. La pérgola debe instalarse en un entorno adecuado, sobre una base estable y nivelada, como una losa de hormigón o bloques de hormigón de 50 x 50 x (D)60 cm en cada poste. Asegúrese de anclar la pérgola al suelo utilizando los tacos de fijación suministrados. Se necesitan al menos dos personas para montar este producto. Monte todas las piezas siguiendo las instrucciones de este manual y no se salte ningún paso. Trate las piezas con extremo cuidado antes y durante el montaje y colóquelas con cuidado en el suelo, evitando pisarlas o colocar objetos sobre ellas. Recomendamos instalar la pérgola en tiempo seco. El incumplimiento de las recomendaciones de instalación invalidará la garantía.

RECOMENDACIONES DE USO

En caso de mal tiempo o nevadas, abra las lamas verticalmente para proteger la pérgola. Esta pérgola puede soportar fuertes lluvias, pero no podemos garantizar una impermeabilidad del 100%. No se suba al techo de la pérgola. No está permitido realizar modificaciones en el producto. Los productos modificados por el usuario no estarán cubiertos por la garantía. En caso de uso indebido del producto, no nos hacemos responsables de los daños o lesiones causados.

GARANTÍA DEL PRODUCTO

La garantía solo se aplicará si se han seguido las instrucciones de montaje, uso y mantenimiento. La garantía no cubre

- El desgaste normal
- Pérdida o rotura de cualquier pieza durante el desembalaje y/o instalación
- Actos vandálicos
- Condiciones climáticas extremas: fuertes vientos, tormentas, granizo, nieve, inundaciones, rayos, etc.

MANTENIMIENTO DEL PRODUCTO

Se recomienda un mantenimiento regular del producto para garantizar su longevidad.

- Lave la pérgola una o dos veces al año con agua dulce utilizando una esponja o paño. No utilice productos agresivos ni superficies abrasivas.
- Compruebe regularmente el apriete de los tornillos (al menos una vez al año).
- Lubrique regularmente los herrajes (al menos una vez al año).
- Asegúrese de que nada obstruya el paso del agua por los canalones (hojas, ramas, etc.).
- Elimine el agua estancada alrededor de las patas de la pérgola (levante las cubiertas).

PT - RECOMENDAÇÕES

Conservar estas instruções durante toda a vida útil do produto. Em função da localização e da superfície, a instalação de uma pérgola pode estar sujeita a uma declaração prévia de obras ou a um pedido de autorização de planeamento. Verificar a regulamentação em vigor antes da instalação. Leia atentamente o manual de instruções antes de instalar a pérgola e verifique se não existem peças danificadas ou em falta. A pérgola deve ser instalada num ambiente adequado, sobre uma base estável e nivelada, como uma laje de betão ou blocos de betão com 50 x 50 x (D)60 cm em cada poste. Não se esqueça de fixar a pérgola ao solo com as buchas de fixação fornecidas. São necessárias pelo menos duas pessoas para montar este produto. Monte todas as peças seguindo as instruções deste manual e não salte nenhuma etapa. Tratar as peças com extremo cuidado antes e durante a montagem e colocá-las cuidadosamente no chão, evitando pisá-las ou colocar objectos sobre elas. Aconselha-se a instalação da pérgola em tempo seco. O não cumprimento das recomendações de instalação implica a anulação da garantia.

RECOMENDAÇÕES DE UTILIZAÇÃO

Em caso de mau tempo ou de queda de neve, abrir as lâminas na vertical para proteger a pérgola. Esta pérgola pode resistir a chuvas fortes, mas não podemos garantir uma impermeabilização a 100%. Não subir para o teto da pérgola. Não é permitido efectuar qualquer modificação no produto. Os produtos modificados pelo utilizador não serão cobertos pela garantia. Em caso de utilização incorrecta do produto, não podemos ser responsabilizados por quaisquer danos ou ferimentos causados.

GARANTIA DO PRODUTO

A garantia só é válida se as instruções de montagem, utilização e manutenção forem respeitadas. A garantia não cobre :

- O desgaste normal
- Perda ou fractura de qualquer peça durante a desembalagem e/ou a instalação
- vandalismo
- Condições climáticas extremas: ventos fortes, tempestades, granizo, neve, inundações, relâmpagos, etc.

MANUTENÇÃO DO PRODUTO

Recomenda-se a manutenção regular do produto para garantir a sua longevidade.

- Lavar a pérgola uma ou duas vezes por ano em água doce com uma esponja ou um pano. Não utilizar um produto agressivo ou uma superfície abrasiva.
- Verificar regularmente o aperto dos parafusos (pelo menos uma vez por ano).
- Lubrificar regularmente as ferragens (pelo menos uma vez por ano).
- Certifique-se de que nada obstrui o fluxo de água através dos algerozes (folhas, ramos, etc.).
- Retire a água estagnada à volta dos pés da pérgola (levante as coberturas).

IT – RACCOMANDAZIONI

Conservare queste istruzioni per tutta la durata del prodotto. A seconda dell'ubicazione e della superficie, l'installazione di una pergola può essere soggetta a una dichiarazione preventiva dei lavori o a una richiesta di autorizzazione edilizia. Prima dell'installazione, verificare la normativa vigente. Prima di installare la pergola, leggere attentamente le istruzioni e verificare che non vi siano parti danneggiate o mancanti. La pergola deve essere installata in un ambiente idoneo, su una base stabile e piana, come una soletta di cemento o blocchi di cemento di 50 x 50 x (P)60 cm per ogni palo. Assicurarsi di ancorare la pergola al terreno utilizzando i tasselli di fissaggio in dotazione. Per il montaggio di questo prodotto sono necessarie almeno due persone. Assemblare tutte le parti seguendo le istruzioni del presente manuale e non saltare alcun passaggio. Trattare le parti con estrema cura prima e durante il montaggio e posizionarle con attenzione sul pavimento, evitando di calpestarle o di appoggiarvi oggetti. Si consiglia di installare la pergola con tempo asciutto. Il mancato rispetto delle raccomandazioni di installazione invalida la garanzia.

RACCOMANDAZIONI PER L'USO

In caso di forte maltempo o nevicata, aprire le lamelle in verticale per proteggere la pergola. Questa pergola può resistere a forti piogge, ma non possiamo garantire un'impermeabilità al 100%. Non salire sul tetto della pergola. Non è consentito apportare modifiche al prodotto. I prodotti modificati dall'utente non sono coperti da garanzia. In caso di uso improprio del prodotto, non possiamo essere ritenuti responsabili per eventuali danni o lesioni causati.

GARANZIA DEL PRODOTTO

La garanzia si applica solo se sono state seguite le istruzioni di montaggio, uso e manutenzione. La garanzia non copre:

- Normale usura
- perdita o rottura di qualsiasi parte durante il disimballaggio e/o l'installazione
- Atti vandalici
- Condizioni atmosferiche estreme: venti forti, tempeste, grandine, neve, inondazioni, fulmini, ecc.

MANUTENZIONE DEL PRODOTTO

Si raccomanda una manutenzione regolare del prodotto per garantirne la durata.

- Lavare la pergola una o due volte l'anno in acqua dolce con una spugna o un panno. Non utilizzare prodotti aggressivi o superfici abrasive.
- Controllare regolarmente il serraggio delle viti (almeno una volta all'anno).
- Oliate regolarmente la ferramenta (almeno una volta all'anno).
- Assicurarsi che nulla ostruisca il flusso dell'acqua attraverso le grondaie (foglie, rami, ecc.).
- Eliminare i ristagni d'acqua intorno alle gambe della pergola (sollevare le coperture).

CARTON 1/6

No.	Profile	Diagram	Size	QTY
AO			116X116 L=2550mm	1
AO-2			116X116 L=2550mm	1
AO-3			116X116 L=2550mm	1





No.	Diagram	QTY
IO		3
JO		3



No.	Diagram	QTY
KO		2
LO		32
LO-1		34
EO-1		1
EO-2		1
EO-3		2
EO-4		2
EO-5		1
MO		66
MO-1		66





No.	Diagram	QTY
TO		12
XO-1		12



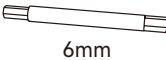

No.	Diagram	QTY
XO-2		34
NO		2
OO-1		2
OO-2		2
PO		2
YO		6
RO		18
SO		68
TO-1		12
UO-1		34

CARTON 1/6









No.	Diagram	QTY
WO	 4x16 PH2	136
WO-1	 5x19	36
XO	 6x40 4mm	66
QO	 6mm	18

No.	Diagram	QTY
ZO-1	 4mm	1
ZO-2	 4mm	1
ZO-3	 6mm	1
ZO-4	 6mm	1

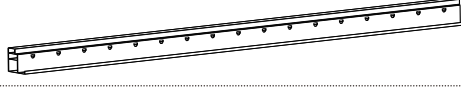

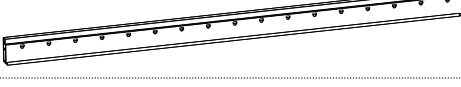

No.	Diagram	QTY
WO-2	 4x19 PH2	2
XO-3	 6x16 4mm	2
VO		168
UO	 lock nut	100

No.	Diagram	QTY
ZO-5	 10mm	1
ZO-6	 PH2	1
ZO-7	 10mm	1
ZO-8		1



CARTON 2/6

No.	Profile	Diagram	Size	QTY
BO-3			75X195 L=2589mm	2
BO-4			75X195 L=2640mm	1
BO-5			75X195 L=2640mm	1
CO-3			75X195 L=3449mm	1
CO-4			75X195 L=3449mm	1



CARTON 2/6

No.	Profile	Diagram	Size	QTY
EO			75X110 L=3366mm	1
FO			27X8 L=2442mm	2
HO			L=1300mm	2



CARTON 3/6

No.	Profile	Diagram	Size	QTY
GO			166X38 L=3366mm	9



CARTON 4/6

No.	Profile	Diagram	Size	QTY
GO			166X38 L=3366mm	9

CARTON 5/6

No.	Profile	Diagram	Size	QTY
GO			166X38 L=3366mm	9

CARTON 6/6

No.	Profile	Diagram	Size	QTY
GO			166X38 L=3366mm	7

**MATÉRIEL NÉCESSAIRE POUR L'INSTALLATION / REQUIRED TOOLS FOR INSTALLATION /
BENÖTIGTES MATERIAL FÜR DIE INSTALLATION / MATERIALEN DIE NODIG ZIJN VOOR DE
INSTALLATIE / MATERIALES NECESARIOS PARA LA INSTALACION / MATERIAIS NECESSARIOS
PARA A INSTALAÇÃO / MATERIALI NECESSARI PER L'INSTALLAZIONE**

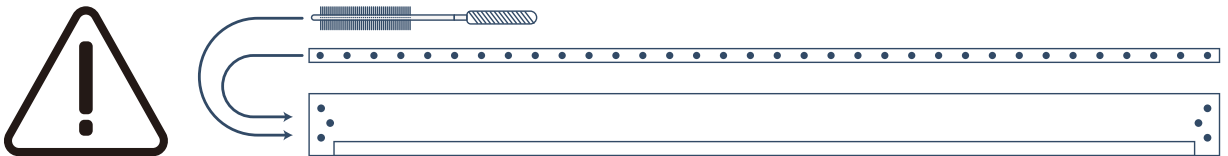
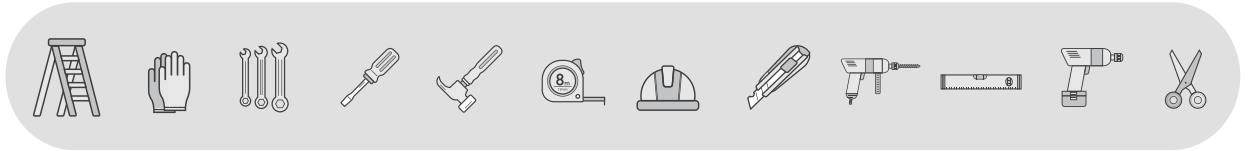

FR. Les lames de pergolas sont fragiles, elles peuvent se déformer légèrement lors de l'installation. Les manipuler avec précaution pour éviter de les endommager.

EN. Pergola louvers are fragile and may warp slightly during installation. Handle with care to avoid damage.

DE. Die Lamellen der Pergola sind zerbrechlich und können sich bei der Montage leicht verformen. Behandeln Sie sie vorsichtig, um Beschädigungen zu vermeiden.

NL. Pergola latten zijn breekbaar en kunnen lichtjes kromtrekken tijdens de installatie. Behandel ze voorzichtig om beschadiging te voorkomen.

ES. Las lamas de la pérgola son frágiles y pueden combarse ligeramente durante la instalación. Manéjelas con cuidado para evitar dañarlas.

PT. As ripas da pérgola são frágeis e podem deformar-se ligeiramente durante a instalação. Manuseie-as com cuidado para não as danificar.

IT. Le lamelle della pergola sono fragili e possono deformarsi leggermente durante l'installazione. Maneggiatele con cura per evitare di danneggiarle.

PLAN DE MONTAGE / ASSEMBLY PLAN / MONTAGEPLAN / MONTAGE TEKENING / PLAN DE MONTAJE / PLANO DE MONTAGEM / PIANO DI MONTAGGIO

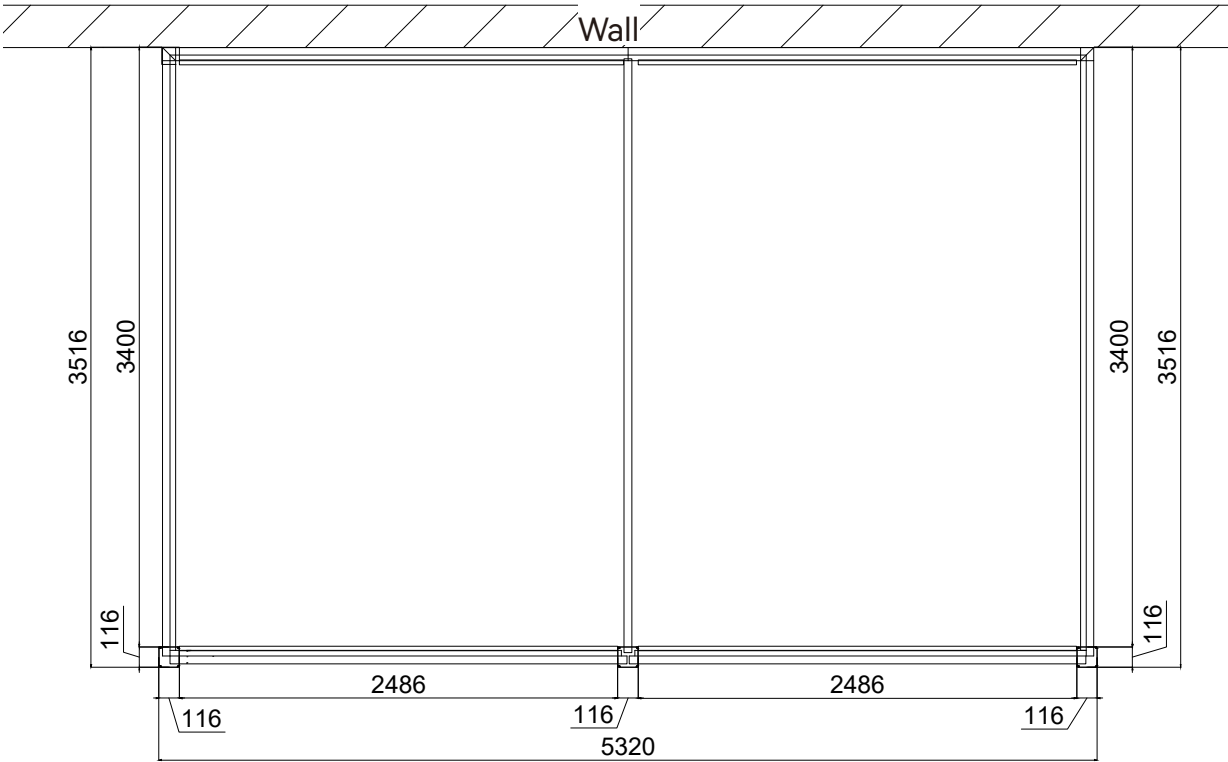

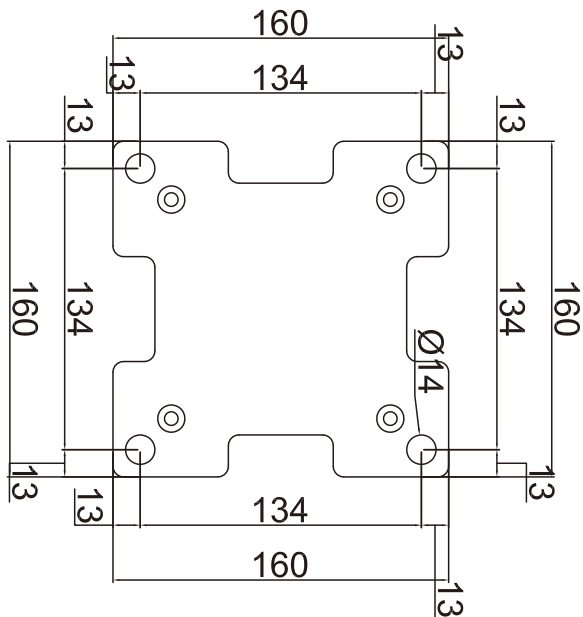
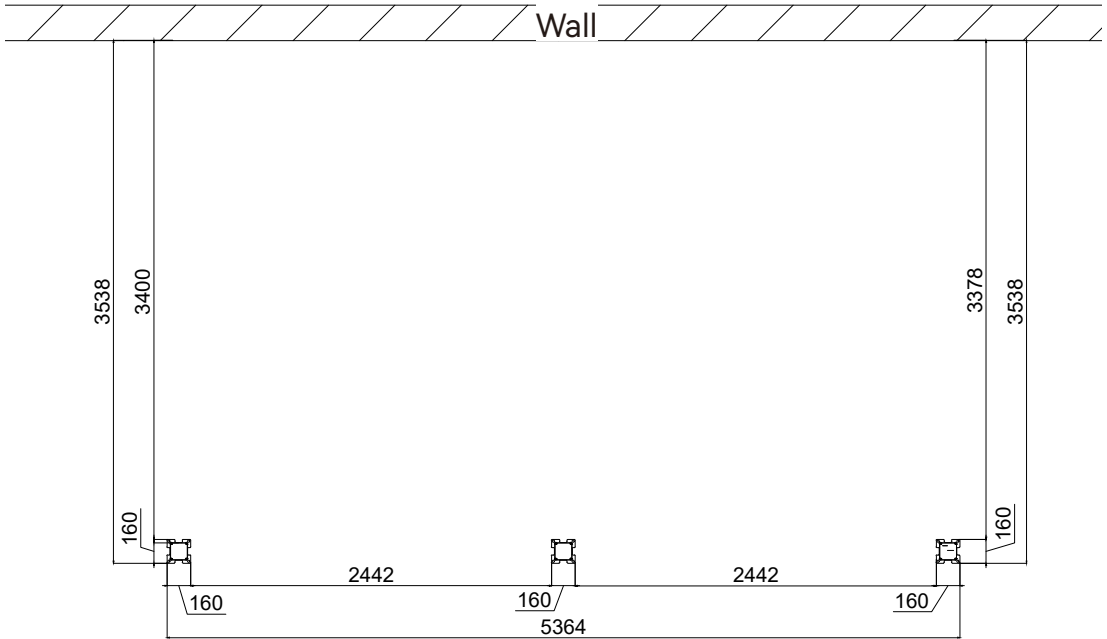

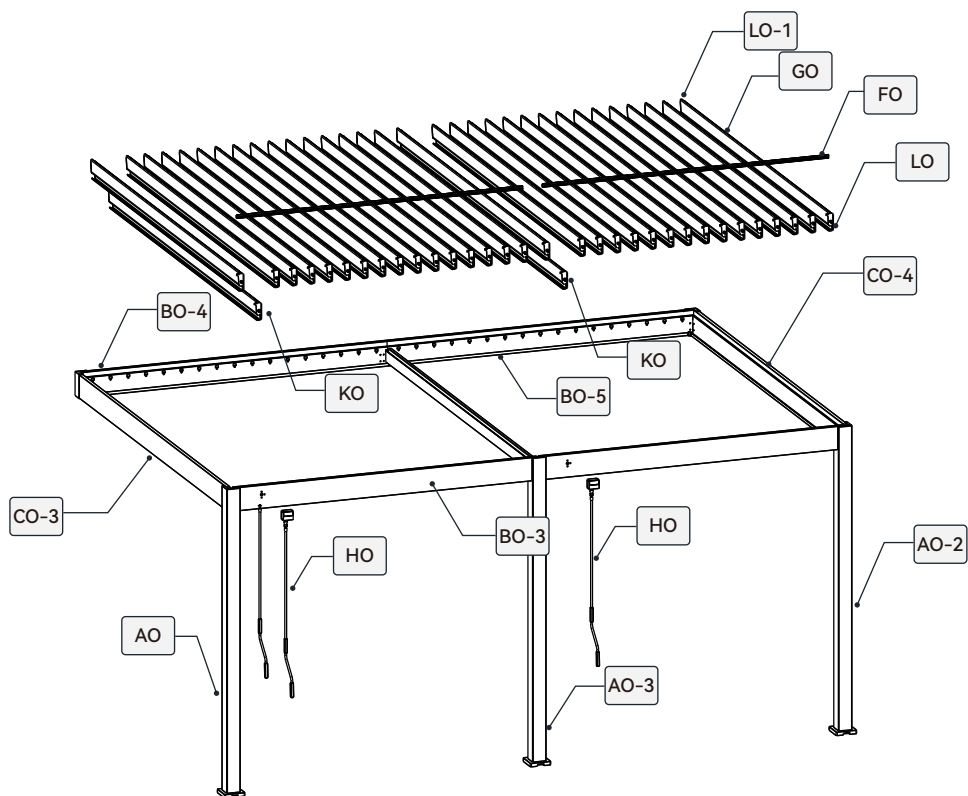

FR. Assembler les pièces comme ci-dessous, à installer aux extrémités des lames.
 EN. Assemble the parts as shown below, to be installed at the ends of the louvers.
 DE. Die Teile wie unten gezeigt zusammenbauen und an den Enden der Lamellen anbringen.
 NL. Monteer de onderdelen zoals hieronder weergegeven, te installeren aan de uiteinden van de lamellen.
 ES. Ensamble las piezas como se muestra a continuación, para instalarlas en los extremos de las lamas.
 PT. Monte as peças conforme mostrado abaixo, para instalar nas extremidades das lâminas.
 IT. Assemblare i pezzi come indicato di seguito, da installare alle estremità delle lame.

KO		2
LO		32
LO-1		34

MO		66
MO-1		66
XO		66

UO		66
VO		66

ZO-1		4mm
ZO-2		4mm
ZO-5		10mm

X32

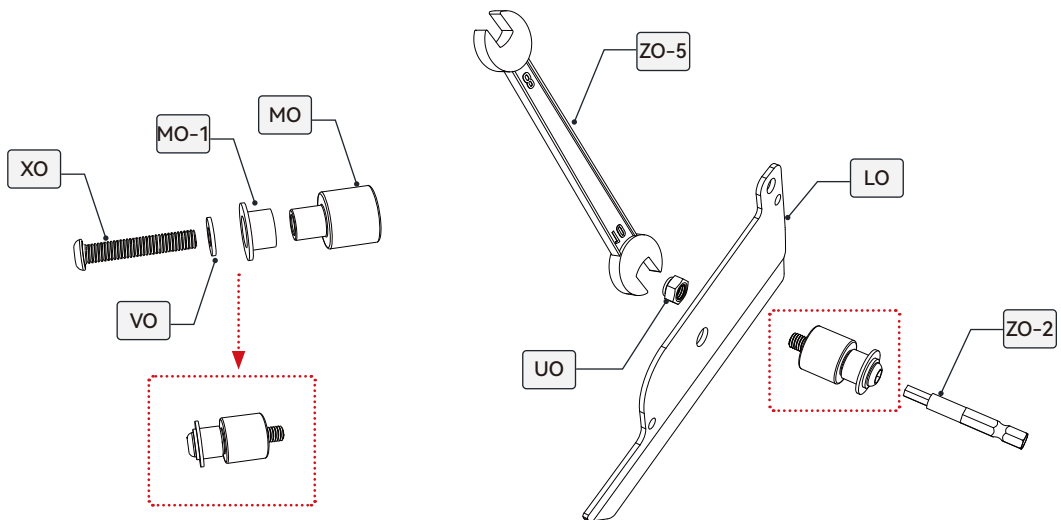

X34

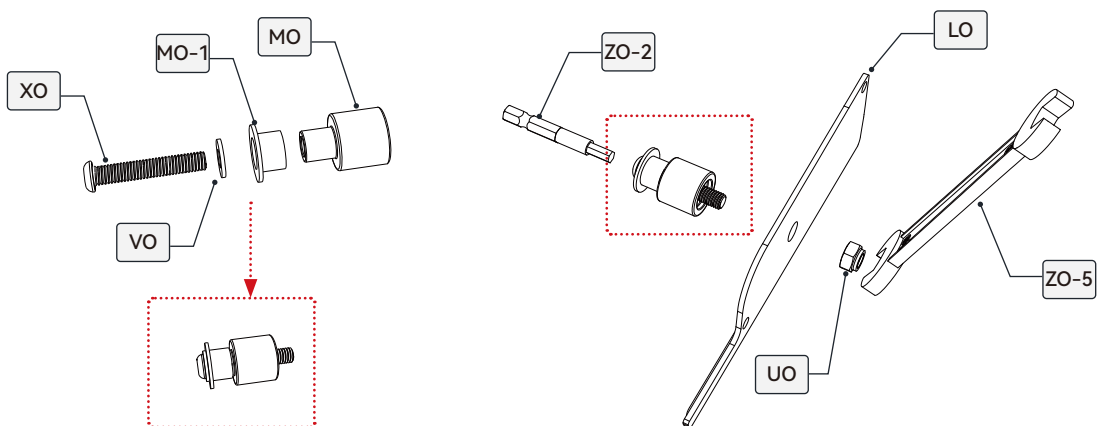

FR. Installer à chaque extrémité des lames, les embouts assemblés précédemment selon les indications ci-dessous.
 EN. Install the previously assembled end caps at each end of the slats as shown below.
 DE. Befestigen Sie an jedem Ende der Lamellen die zuvor gemäß den folgenden Anweisungen zusammengebauten Endkappen.
 NL. Installeer aan elk uiteinde van de lamellen de eerder gemonteerde eindstukken volgens onderstaande instructies.
 ES. Instale en cada extremo de las lamas los tapones ensamblados previamente según las indicaciones siguientes.
 PT. Instale em cada extremidade das lâminas as pontas montadas anteriormente, conforme as indicações abaixo.
 IT. Installare alle estremità delle lame i terminali assemblati in precedenza secondo le indicazioni riportate di seguito.

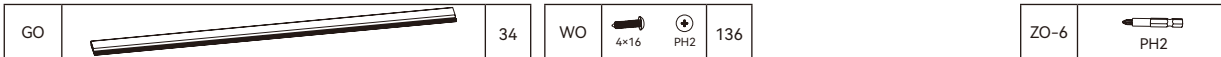

X2

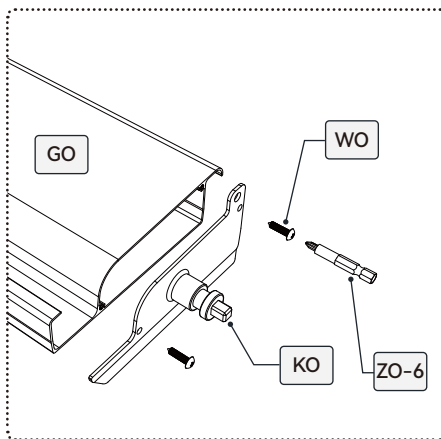
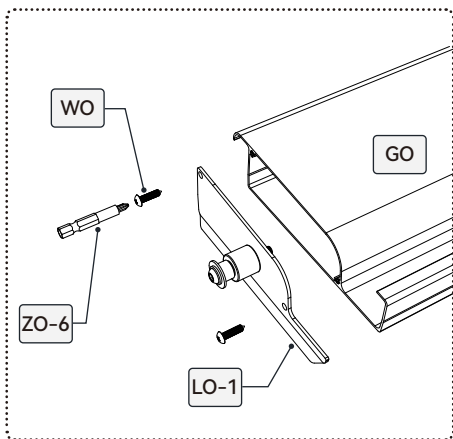
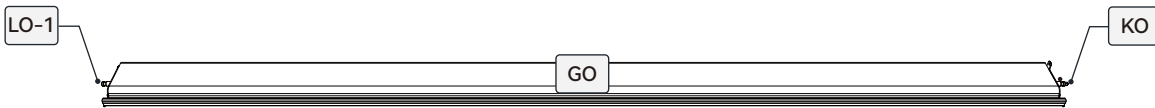

X32

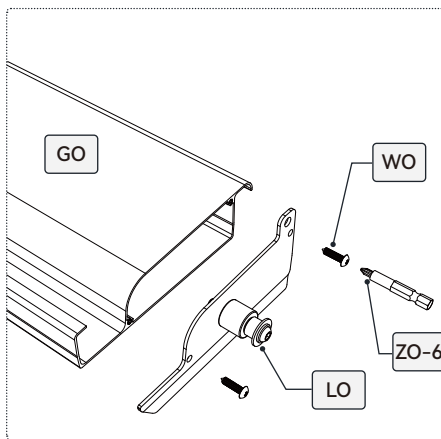
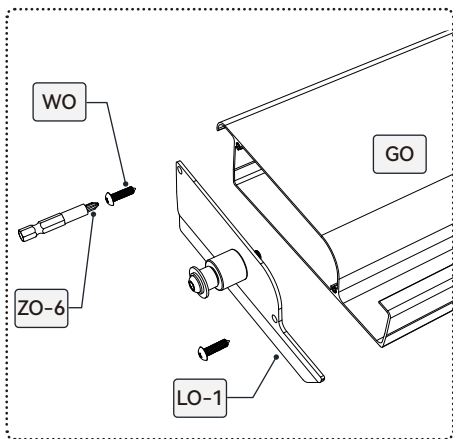

FR. Glisser les caches sur les poteaux, puis fixer les platines. Vérifier que l'ouverture du cache correspond bien à celle du poteau.

EN. Slide the covers onto the posts, then attach the plates. Check that the opening of the cover matches that of the post.

DE. Schieben Sie die Abdeckungen auf die Pfosten und befestigen Sie dann die Platten. Vergewissern Sie sich, dass die Öffnung der Abdeckung mit der des Pfostens übereinstimmt.

NL. Schuif de afdekkappen op de palen en bevestig vervolgens de platen. Controleer of de opening van de afdekkap overeenkomt met die van de paal.

ES. Deslice las tapas sobre los postes y fije las placas. Compruebe que la abertura de la tapa coincida con la del poste.

PT. Deslize as tampas sobre os postes e, em seguida, fixe as placas. Verifique se a abertura da tampa corresponde à do poste.

IT. Far scorrere i copriestremità sui montanti, quindi fissare le piastre. Verificare che l'apertura del copriestremità corrisponda a quella del montante.

AO		1
AO-2		1
AO-3		1





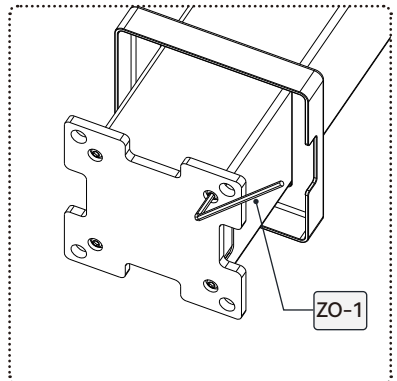
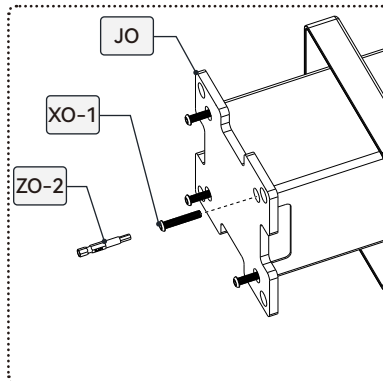
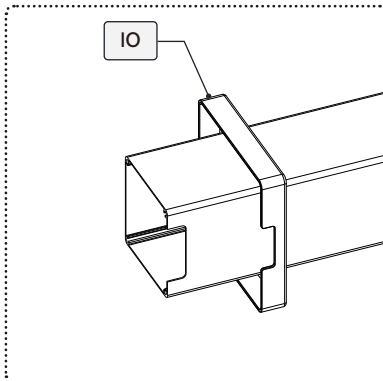
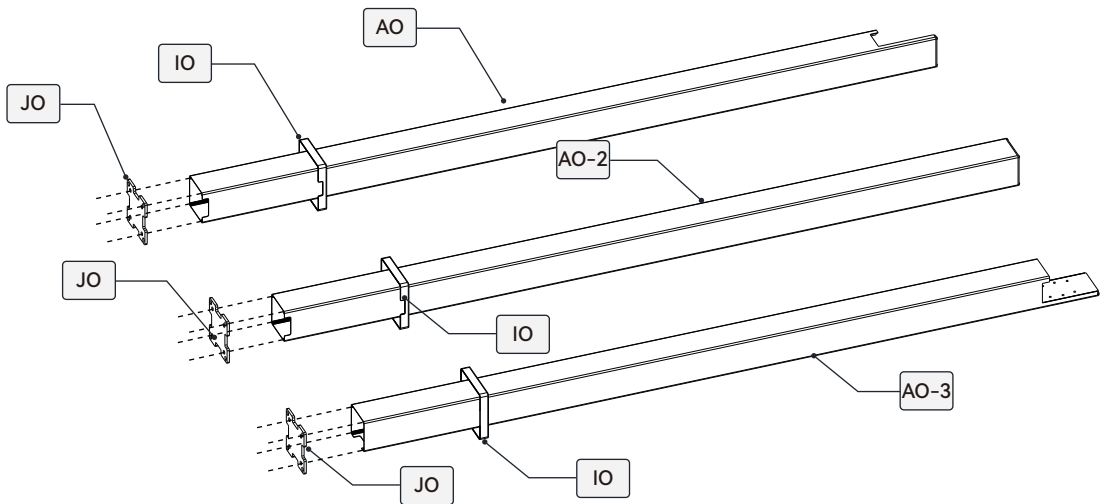

IO		3
JO		3

XO-1		12
------	--	----

ZO-1	
ZO-2	



FR. Ajouter les connecteurs aux extrémités des poutres murales.
 EN. Add connectors to the ends of the wall beams.
 DE. Die Verbinder an den Enden der Wandträger anbringen.
 NL. Voeg de connectoren toe aan de uiteinden van de muurbalk.
 ES. Añadir los conectores a los extremos de las vigas de pared.
 PT. Adicione os conectores às extremidades das vigas da parede.
 IT. Aggiungere i connettori alle estremità delle travi murali.

BO-4		1	EO-4		2	EO-3		2	ZO-7	 8mm
BO-5		1	EO-5		1	WO-1	 5x19	16		

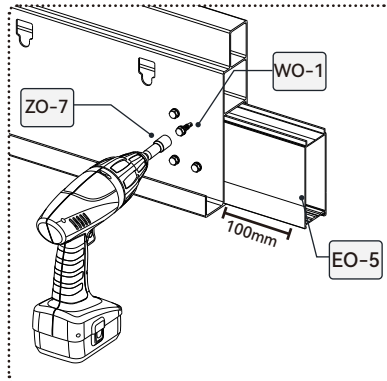
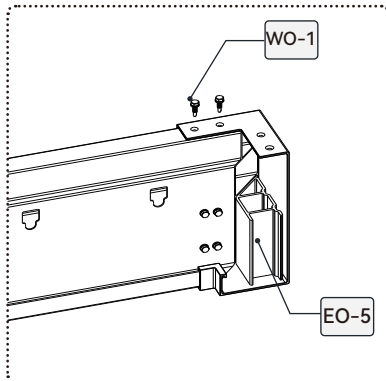
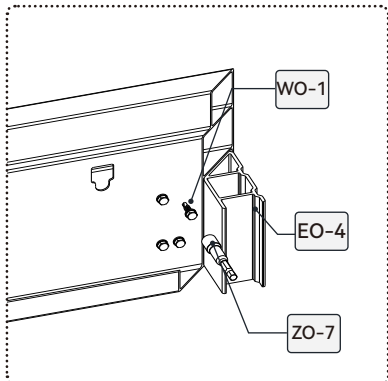
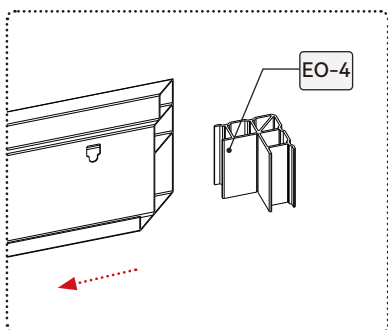
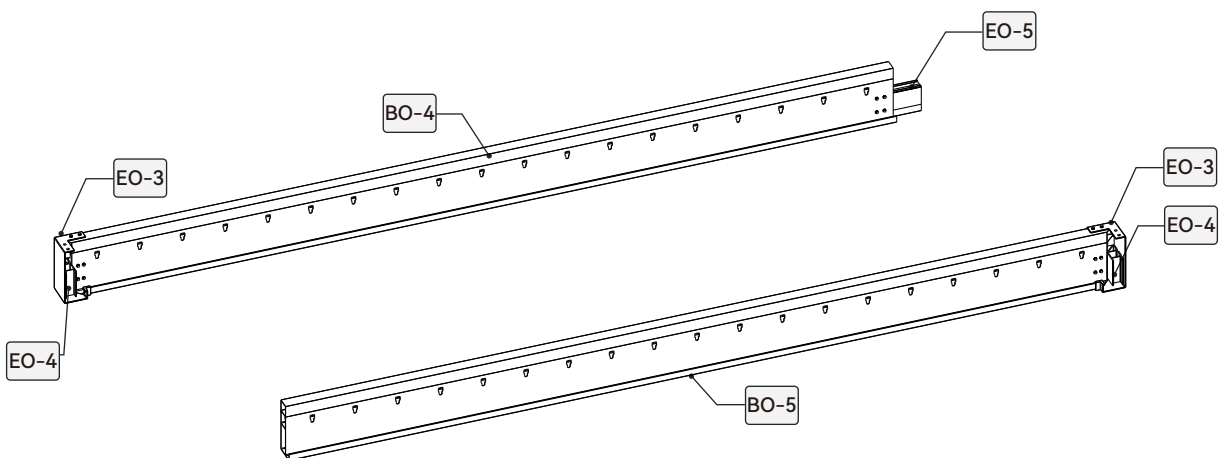

FR. Assembler les 2 poutres murales ensemble.
 EN. Assemble the two wall beams together.
 DE. Die beiden Wandbalken miteinander verbinden.
 NL. De 2 muurbalken aan elkaar bevestigen.
 ES. Ensamblar las dos vigas de pared.
 PT. Junte as duas vigas de parede.
 IT. Assemblare le 2 travi murali insieme.

WO-1	 5x19	 8mm	4
------	--	---	---

ZO-7	 8mm
------	---

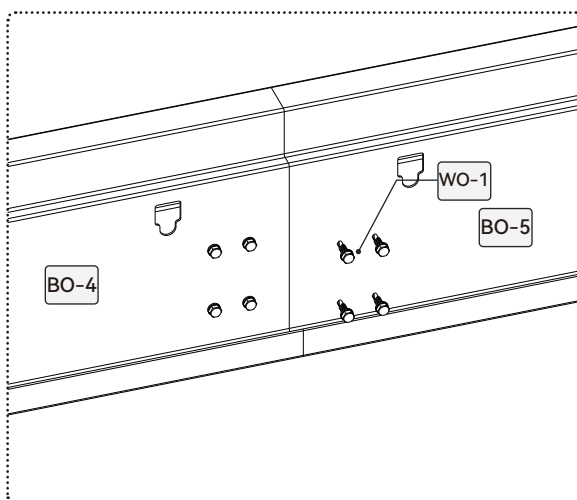
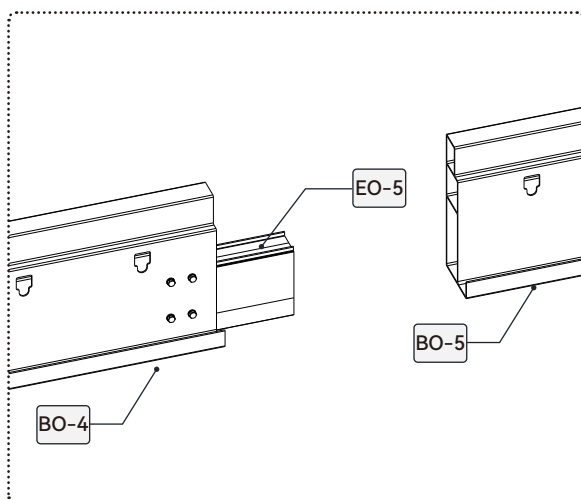
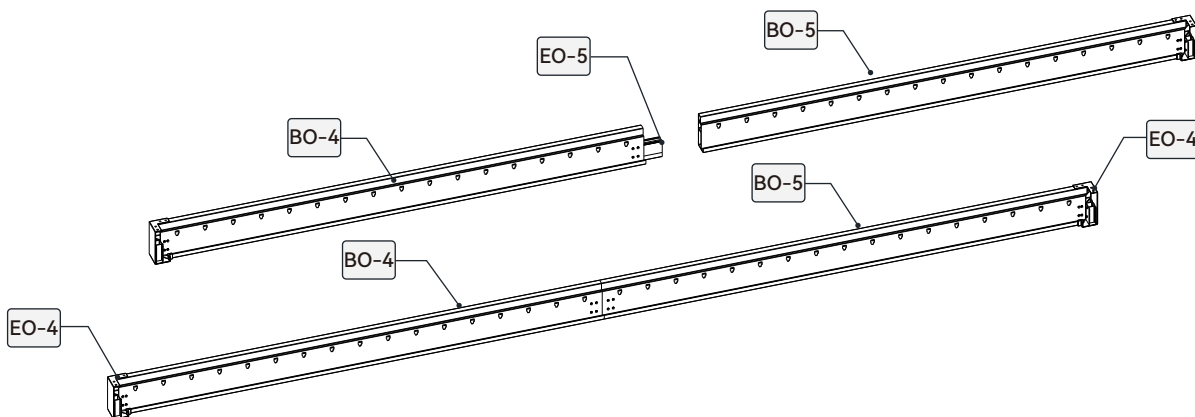

FR. Positionner la poutre sur le mur à la hauteur indiquée ci-dessous. Repérer les points de perçage et percer les trous avec un foret M8x150.

EN. Position the beam on the wall at the height indicated below. Mark the drilling points and drill the holes with an M8x150 drill bit.

DE. Positionieren Sie den Balken in der unten angegebenen Höhe an der Wand. Markieren Sie die Bohrpunkte und bohren Sie die Löcher mit einem M8x150-Bohrer.

NL. Plaats de balk op de muur op de hieronder aangegeven hoogte. Markeer de boorpunten en boor de gaten met een boor M8x150.

ES. Coloque la viga en la pared a la altura indicada a continuación. Marque los puntos de perforación y taladre los agujeros con una broca M8x150.

PT. Positionner la poutre sur le mur à la hauteur indiquée ci-dessous. Repérer les points de perçage et percer les trous avec un foret M8x150.

IT. Posizionare la trave sulla parete all'altezza indicata di seguito. Segnare i punti di foratura e praticare i fori con una punta da trapano M8x150.

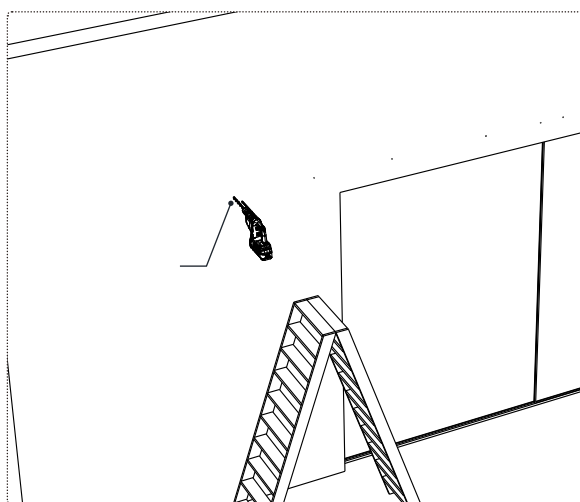
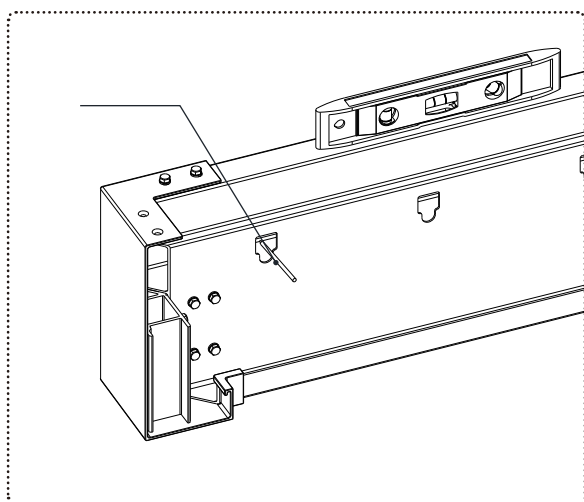
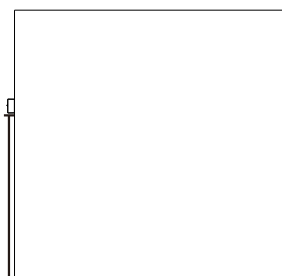
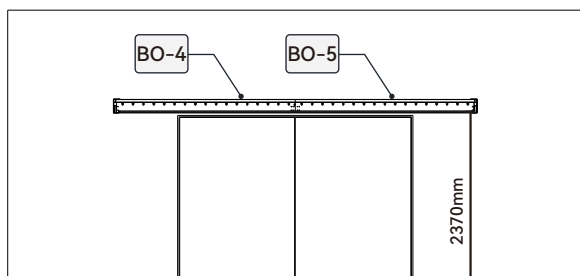
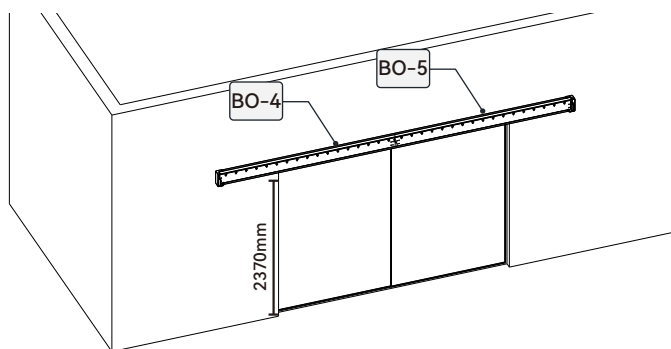

FR. Fixer la poutre au mur en utilisant des vis à expansion dans les trous pré-perçés.
 EN. Secure the beam to the wall using expansion screws in the pre-drilled holes.
 DE. Befestigen Sie den Balken mit Dübeln in den vorgebohrten Löchern an der Wand.
 NL. Bevestig de balk aan de muur met behulp van expansieschroeven in de voorgeboorde gaten.
 ES. Fije la viga a la pared utilizando tornillos de expansión en los orificios pretaladrados.
 PT. Fixar a viga à parede utilizando parafusos de expansão nos orifícios pré-perfurados.
 IT. Fissare la trave alla parete utilizzando viti ad espansione nei fori preforati.

TO-1	 8x100	12
------	---	----

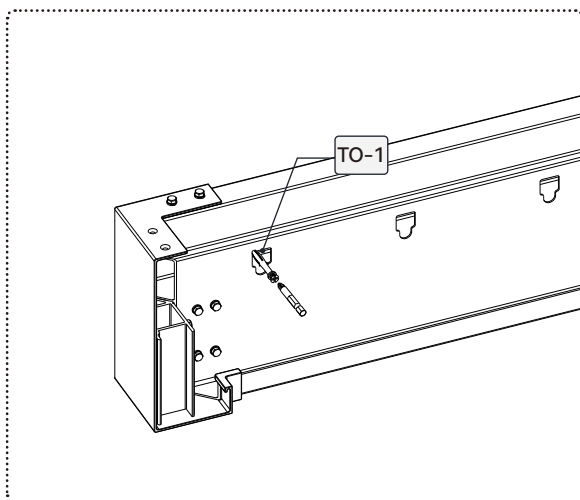
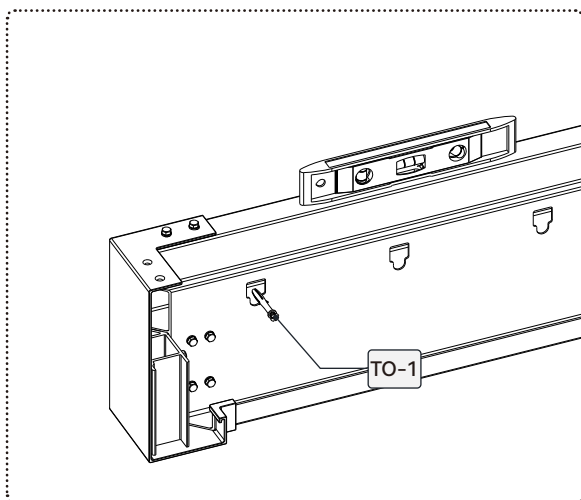

FR. Installer les poutres latérales sur les poteaux.
 EN. Install the side beams on the posts.
 DE. Die Seitenträger an den Pfosten anbringen.
 NL. Installeer de zijbalken op de palen.
 ES. Instalar las vigas laterales en los postes.
 PT. Instale as vigas laterais nos postes.
 IT. Installare le travi laterali sui pali.

CO-3		1
CO-4		1

QO			6
----	---	---	---

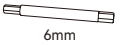
ZO-3		6mm
ZO-4		6mm

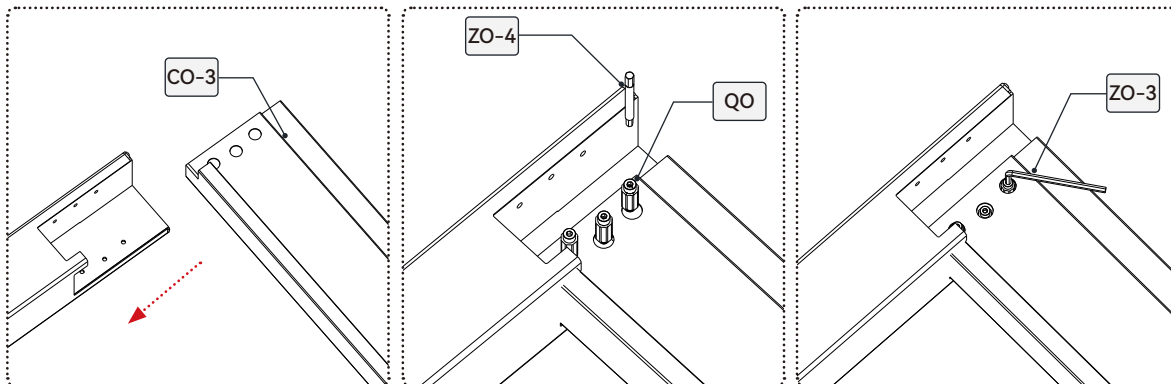
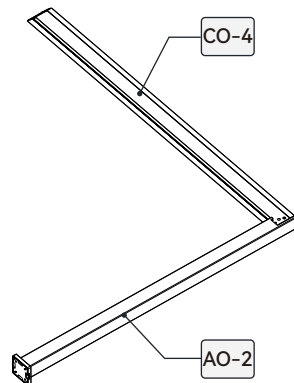
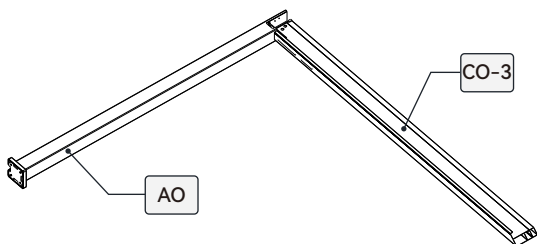

FR. Assembler l'ensemble sur la poutre murale, puis ajouter les poutres à l'avant.

EN. Assemble the unit on the wall beam, then add the beams at the front.

DE. Montieren Sie die Baugruppe auf dem Wandträger und fügen Sie dann die Träger an der Vorderseite hinzu.

NL. Monteer het geheel op de muurbalk en voeg vervolgens de balken aan de voorkant toe.

ES. Ensamble todo en la viga de pared y luego agregue las vigas en la parte delantera.

PT. Monte o conjunto na viga da parede e, em seguida, adicione as vigas à frente.

IT. Assemblare il tutto sulla trave a muro, quindi aggiungere le travi anteriori.

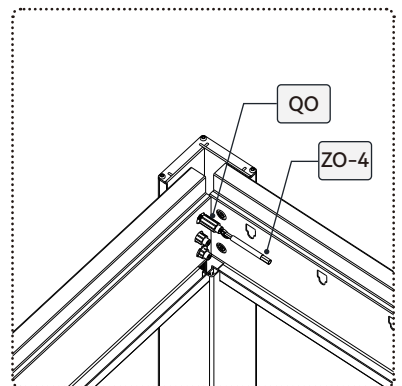
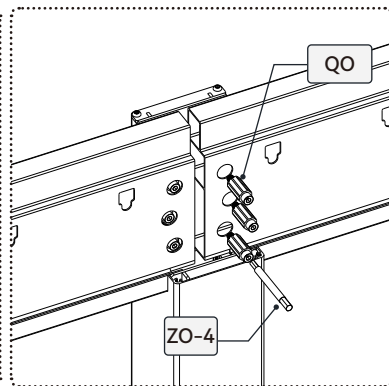
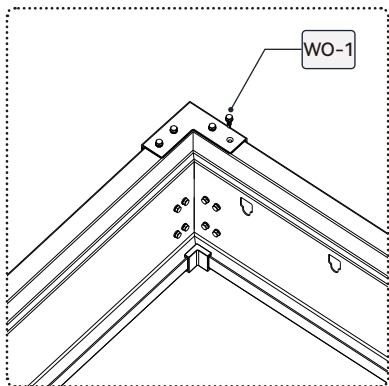
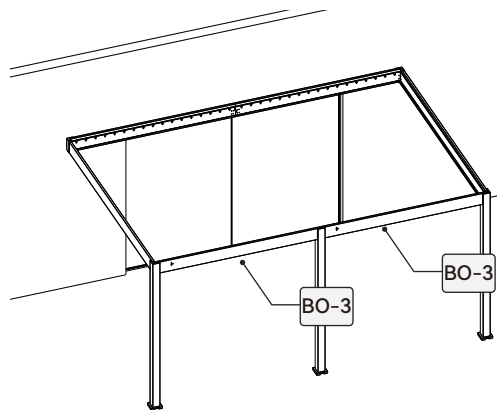
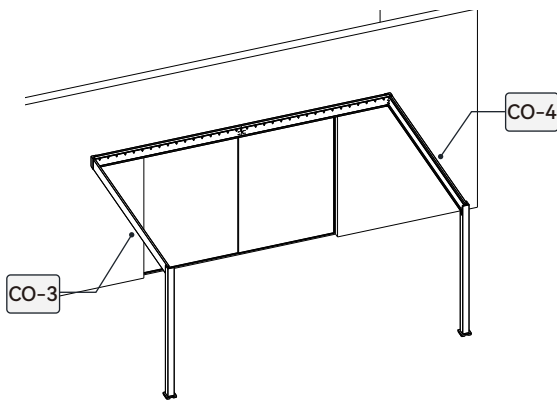
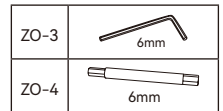
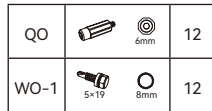
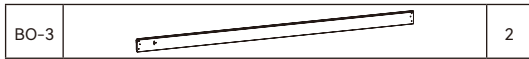

FR. Vérifier les dimensions ci-dessous avant de poursuivre le montage. Utiliser un niveau à bulle pour s'assurer que toutes les poutres sont de niveau et que les poteaux sont perpendiculaires au sol (à un angle de 90°). Vérifier l'alignement vertical des poteaux. Ajuster le bord inférieur des poteaux selon les dimensions indiquées sur le schéma. Utiliser une perceuse à percussion de 12mm pour percer les trous, puis insérer les boulons d'ancrage et serrer-les à l'aide d'une clé M17.

EN. Check the dimensions below before continuing with assembly. Use a spirit level to ensure that all beams are level and that the posts are perpendicular to the ground (at a 90° angle). Check the vertical alignment of the posts. Adjust the bottom edge of the posts according to the dimensions indicated on the diagram. Use a 12mm hammer drill to drill the holes, then insert the anchor bolts and tighten them with an M17 wrench.

DE. Überprüfen Sie die unten angegebenen Maße, bevor Sie mit der Montage fortfahren. Verwenden Sie eine Wasserwaage, um sicherzustellen, dass alle Balken waagrecht und die Pfosten senkrecht zum Boden (im Winkel von 90°) stehen. Überprüfen Sie die vertikale Ausrichtung der Pfosten. Passen Sie die Unterkante der Pfosten gemäß den in der Zeichnung angegebenen Maßen an. Bohren Sie mit einem 12-mm-Schlagbohrer die Löcher, setzen Sie dann die Ankerbolzen ein und ziehen Sie sie mit einem M17-Schlüssel fest.

NL. Controleer de onderstaande afmetingen voordat u verdergaat met de montage. Gebruik een waterpas om te controleren of alle balken waterpas zijn en of de palen loodrecht op de grond staan (in een hoek van 90°). Controleer of de palen verticaal zijn uitgelijnd. Pas de onderkant van de palen aan volgens de afmetingen op de tekening. Gebruik een 12 mm boormachine om de gaten te boren, plaats vervolgens de ankerbouten en draai ze vast met een M17-sleutel.

ES. Verifier les dimensions ci-dessous avant de poursuivre le montage. Utiliser un niveau à bulle pour s'assurer que toutes les poutres sont de niveau et que les poteaux sont perpendiculaires au sol (à un angle de 90°). Vérifier l'alignement vertical des poteaux. Ajuster le bord inférieur des poteaux selon les dimensions indiquées sur le schéma. Utiliser une perceuse à percussion de 12mm pour percer les trous, puis insérer les boulons d'ancrage et serrer-les à l'aide d'une clé M17.

PT. Verifique as dimensões abaixo antes de continuar a montagem. Use um nível de bolha para garantir que todas as vigas estejam niveladas e que os postes estejam perpendiculares ao solo (em um ângulo de 90°). Verifique o alinhamento vertical dos postes. Ajuste a borda inferior dos postes de acordo com as dimensões indicadas no esquema. Utilize uma broca de percussão de 12 mm para fazer os furos, insira os parafusos de fixação e aperte-os com uma chave M17.

IT. Controllare le dimensioni riportate di seguito prima di procedere con il montaggio. Utilizzare una livella a bolla per assicurarsi che tutte le travi siano livellate e che i pali siano perpendicolari al suolo (con un angolo di 90°). Verificare l'allineamento verticale dei pali. Regolare il bordo inferiore dei pali secondo le dimensioni indicate nello schema. Utilizzare un trapano a percussione da 12 mm per praticare i fori, quindi inserire i bulloni di ancoraggio e serrarli con una chiave M17.

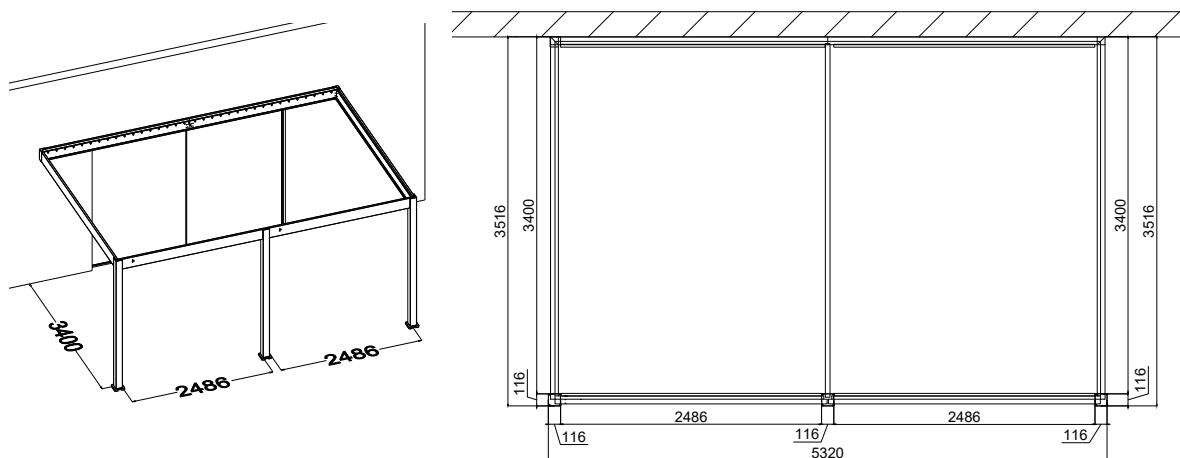

TO	 10x80	12
----	---	----

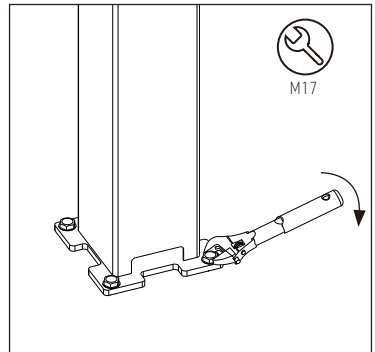
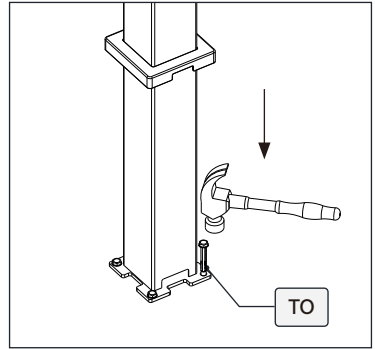
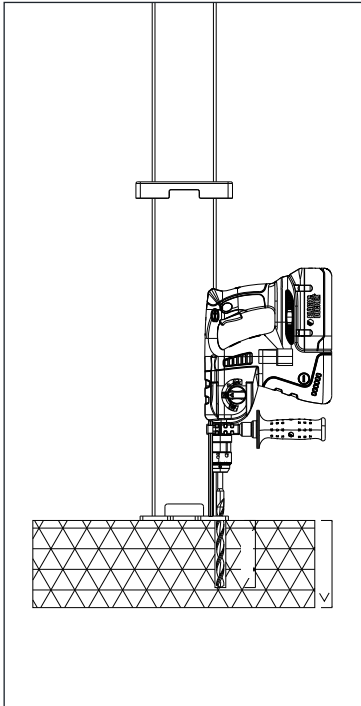
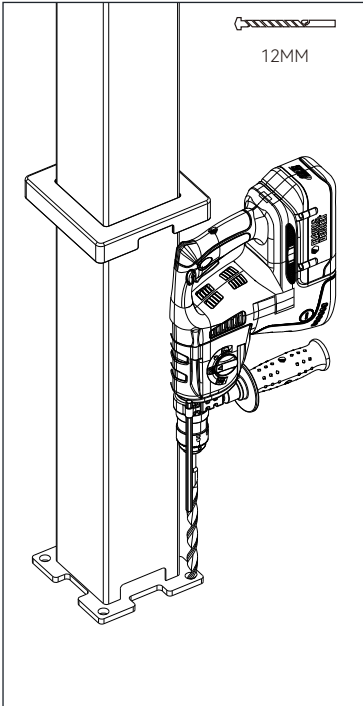

FR. Appliquer un cordon de mastic de silicone au niveau des jonctions de la poutre murale, afin d'assurer une connexion étanche.

EN. Apply a bead of silicone sealant to the joints of the wall beam to ensure a watertight connection.

DE. Tragen Sie eine Silikondichtungsmasse auf die Verbindungsstellen des Wandträgers auf, um eine dichte Verbindung zu gewährleisten.

NL. Breng een laag siliconenkit aan op de verbindingen van de muurbalk om een waterdichte verbinding te garanderen.





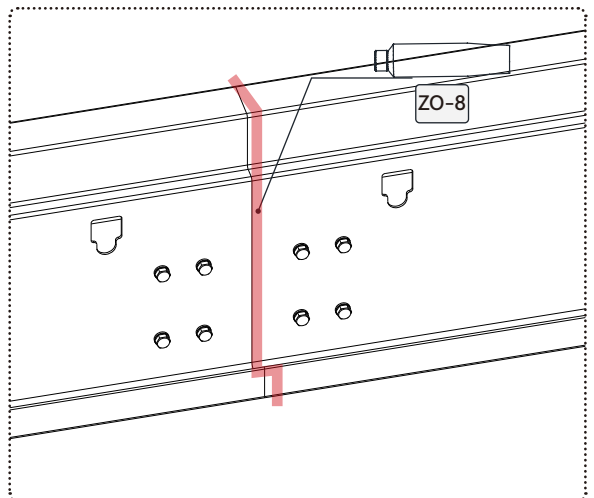
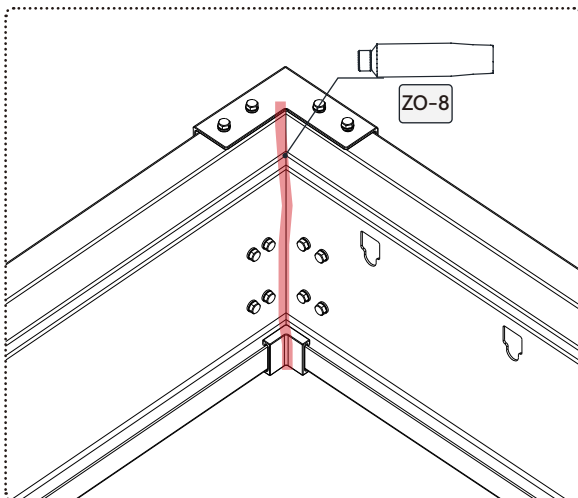
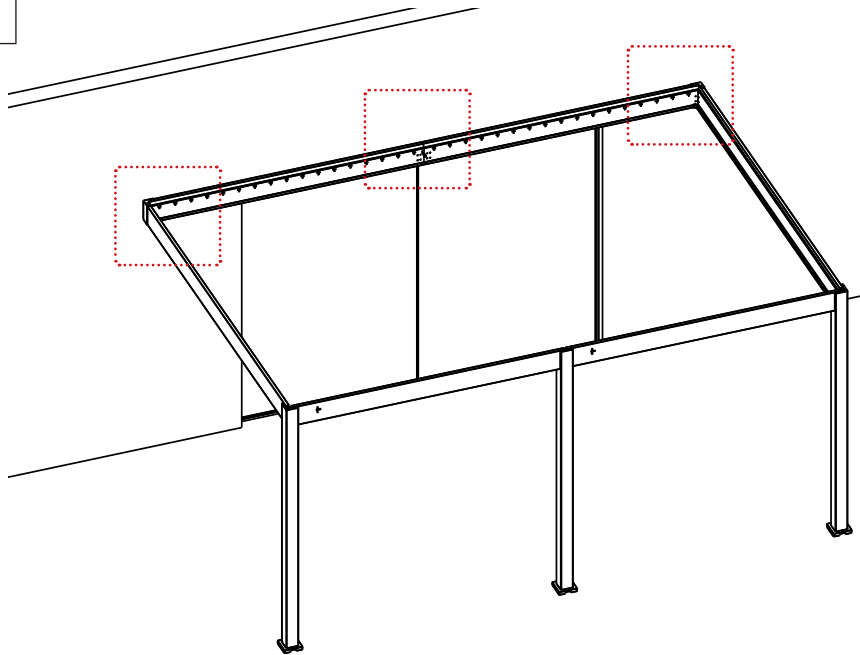
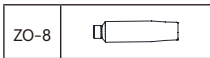

ES. Aplique una capa de sellador de silicona en las uniones de la viga de pared para garantizar una conexión hermética.

PT. Aplique uma camada de silicone nas juntas da viga da parede, para garantir uma conexão estanque.

IT. Applicare un cordone di mastice siliconico in corrispondenza dei giunti della trave murale, per garantire una connessione a tenuta stagna.







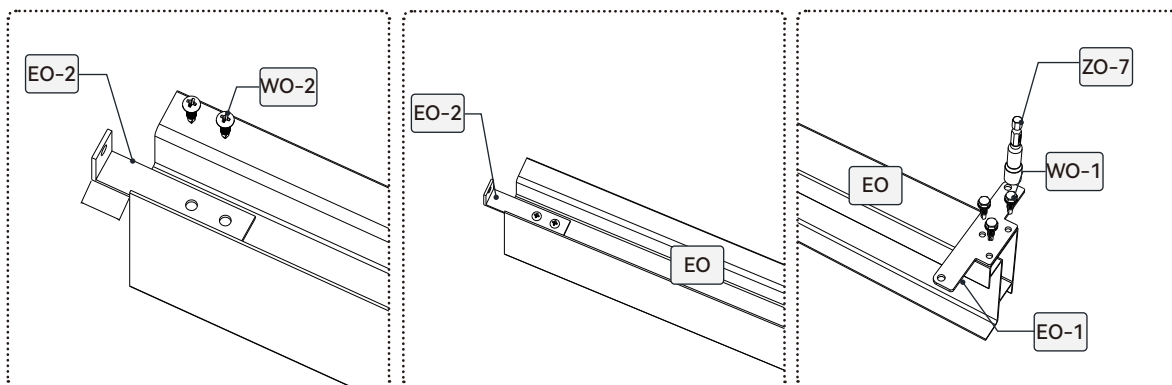
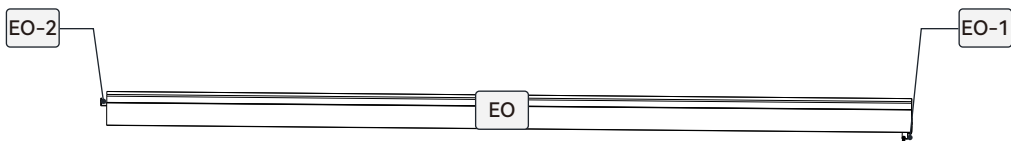

FR. Fixer les connecteurs aux extrémités de la poutre intermédiaire.
 EN. Attach the connectors to the ends of the intermediate beam.
 DE. Befestigen Sie die Verbinder an den Enden des Zwischenträgers.
 NL. Bevestig de connectoren aan de uiteinden van de tussenbalk.
 ES. Fijar los conectores a los extremos de la viga intermedia.
 PT. Fixar os conectores nas extremidades da viga intermédia.
 IT. Fissare i connettori alle estremità della trave intermedia.

EO		1	EO-1		1	WO-1	 5x19	 5mm	3	ZO-7	 8mm
			EO-2		1	WO-2	 4x19 PH2		2		



FR. Installer la poutre intermédiaire entre les deux poteaux et la fixer à l'aide des connecteurs.
 EN. Install the intermediate beam between the two posts and secure it using the connectors.
 DE. Den Zwischenbalken zwischen den beiden Pfosten einbauen und mit den Verbindungsstücken befestigen.
 NL. Installeer de tussenbalk tussen de twee palen en bevestig deze met behulp van de verbindingsstukken.
 ES. Instale la viga intermedia entre los dos postes y fíjela con los conectores.
 PT. Instale a viga intermediária entre os dois postes e fixe-a com os conectores.
 IT. Installare la trave intermedia tra i due montanti e fissarla con i connettori.

WO-1	 5x19	 5mm	1
XO-3	 6x16	 4mm	2

ZO-1	 4mm
ZO-7	 8mm

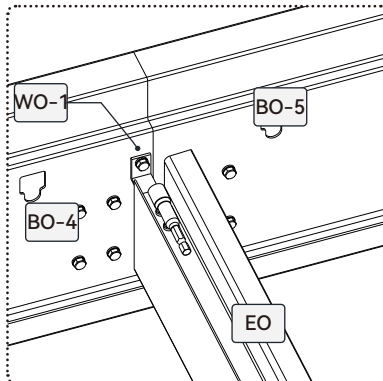
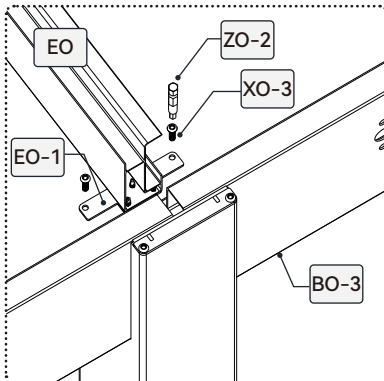
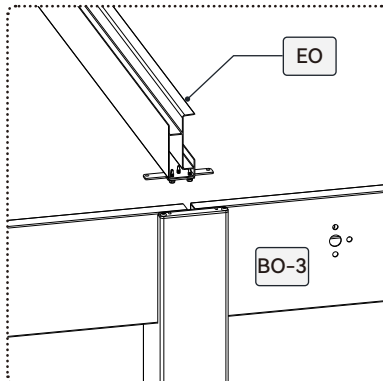
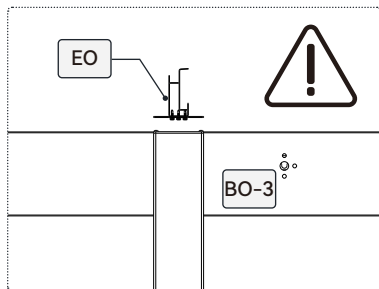
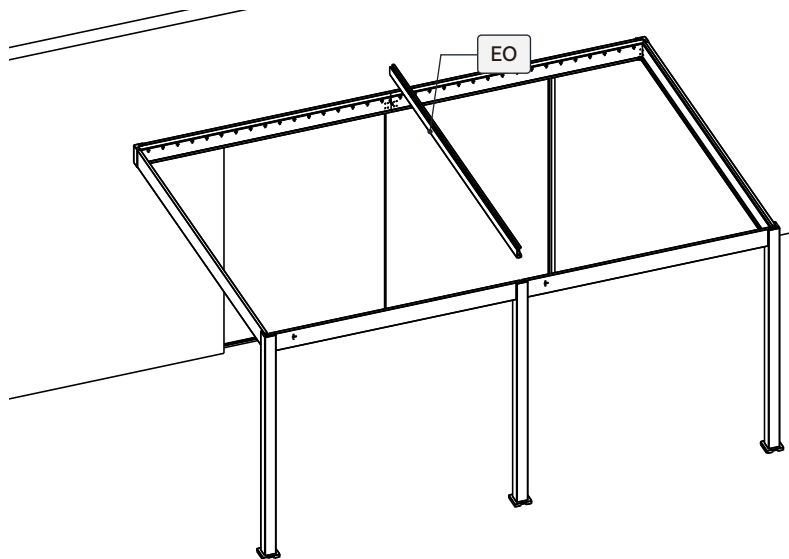

FR. Installer la première lame. Insérer complètement une extrémité dans l'ouverture pratiquée dans la poutre, puis engager l'autre extrémité.

EN. Install the first blade. Insert one end completely into the opening in the beam, then engage the other end.

DE. Die erste Diele verlegen. Ein Ende vollständig in die Öffnung im Balken einführen und dann das andere Ende einrasten lassen.

NL. Installeer de eerste plank. Steek het ene uiteinde volledig in de opening in de balk en plaats vervolgens het andere uiteinde.

ES. Instale la primera lama. Inserte completamente un extremo en la abertura practicada en la viga y, a continuación, encaje el otro extremo.

PT. Instale a primeira lâmina. Insira completamente uma extremidade na abertura feita na viga e, em seguida, encaixe a outra extremidade.

IT. Installare la prima lama. Inserire completamente un'estremità nell'apertura praticata nella trave, quindi inserire l'altra estremità.

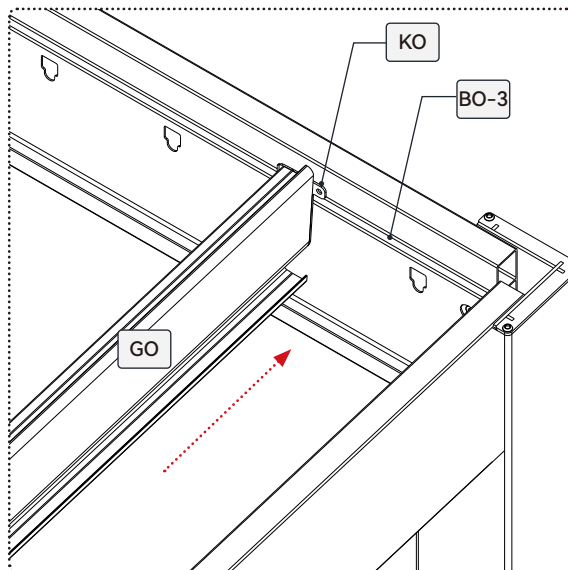
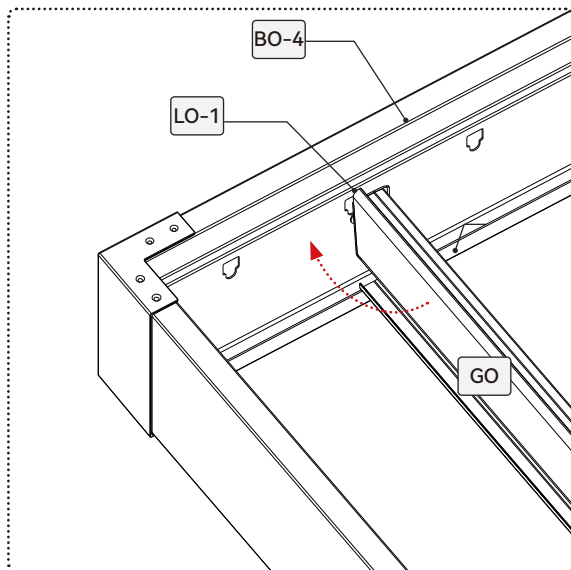
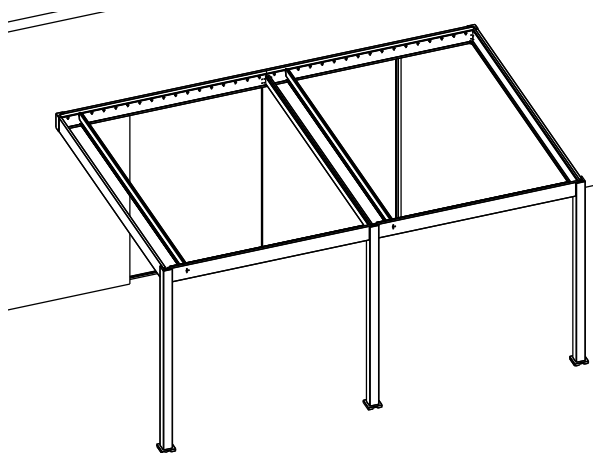
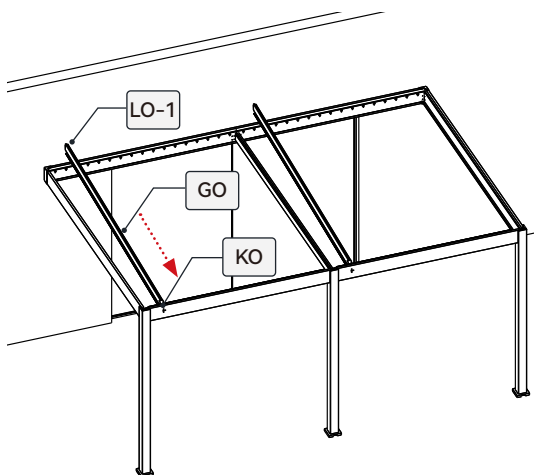

FR. Ajouter progressivement les autres lames ainsi que les caches afin d'accéder facilement aux trous.

EN. Gradually add the other blades and covers so that the holes are easily accessible.

DE. Fügen Sie nach und nach die anderen Lamellen sowie die Abdeckungen hinzu, um leicht an die Löcher heranzukommen.

NL. Voeg geleidelijk de andere lamellen en afdekkappen toe, zodat u gemakkelijk bij de gaten kunt komen.

ES. Añada progresivamente las demás láminas y las tapas para poder acceder fácilmente a los orificios.

PT. Adicione gradualmente as outras lâminas e as tampas para facilitar o acesso aos orifícios.

IT. Aggiungere gradualmente le altre lame e le coperture per poter accedere facilmente ai fori.

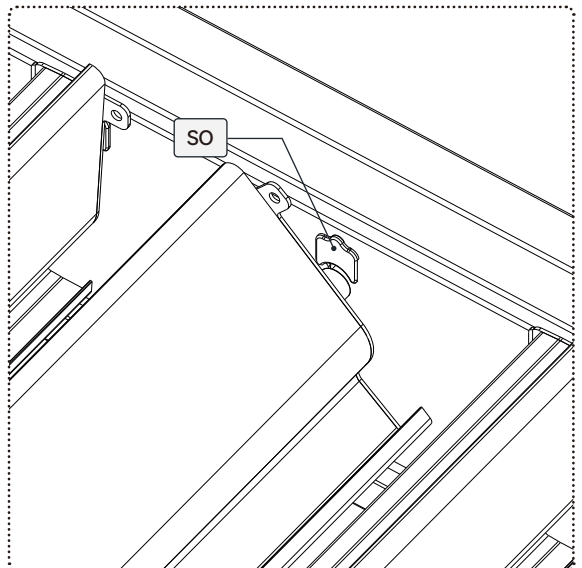
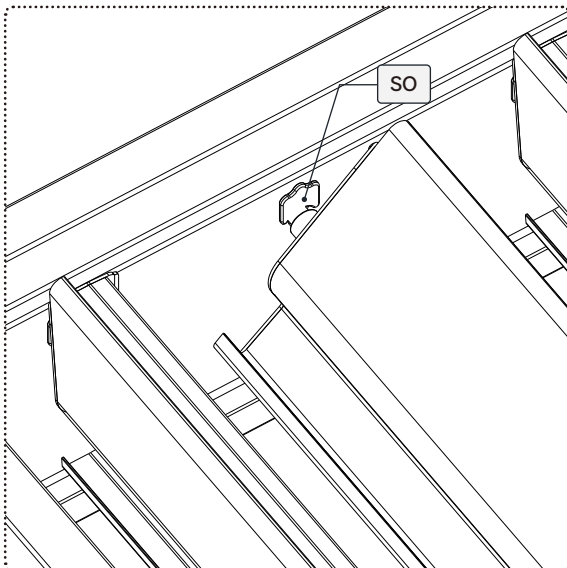
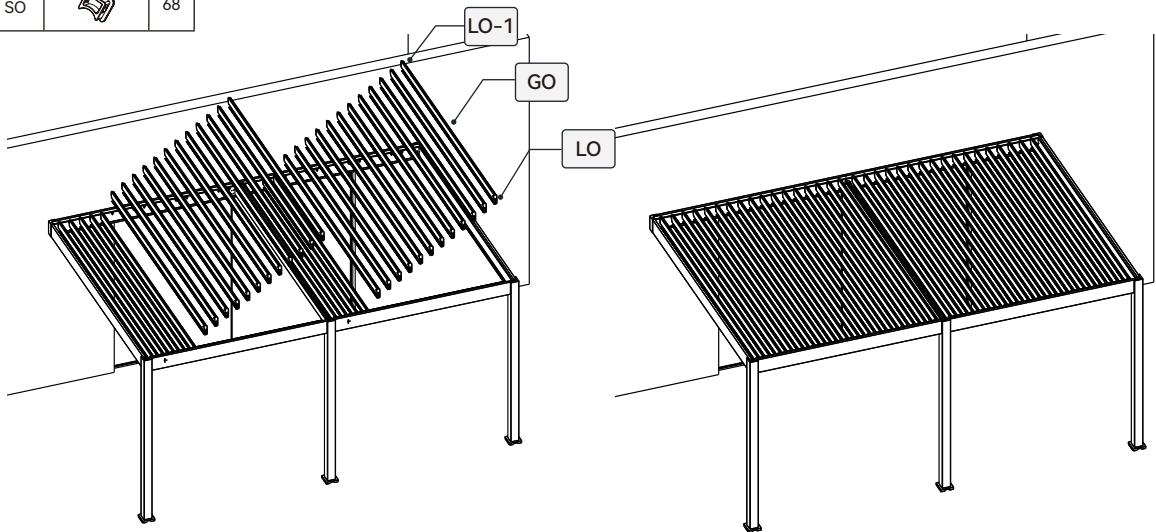

FR. Repérer les trous de fixation sur la poutre avant, insérer le cylindre puis ajouter les éléments constituant le boîtier manivelle.

EN. Mark the mounting holes on the front beam, insert the cylinder, then add the components that make up the crank box.



DE. Markieren Sie die Befestigungslöcher am vorderen Balken, setzen Sie den Zylinder ein und fügen Sie die Elemente hinzu, aus denen das Kurbelgehäuse besteht.



NL. Zoek de bevestigingsgaten op de voorste balk, steek de cilinder erin en voeg vervolgens de onderdelen van de hendelkast toe.

ES. Localice los orificios de fijación en la viga delantera, inserte el cilindro y añada los elementos que componen la caja de la manivela.



PT. Localize os orifícios de fixação na viga dianteira, insira o cilindro e adicione os elementos que constituem a caixa da manivela.

IT. Individuare i fori di fissaggio sulla trave anteriore, inserire il cilindro, quindi aggiungere gli elementi che costituiscono la scatola della manovella.

OO-1		2
OO-2		2

PO		2
NO		2

YO		6
----	---	---

ZO-1	
ZO-2	

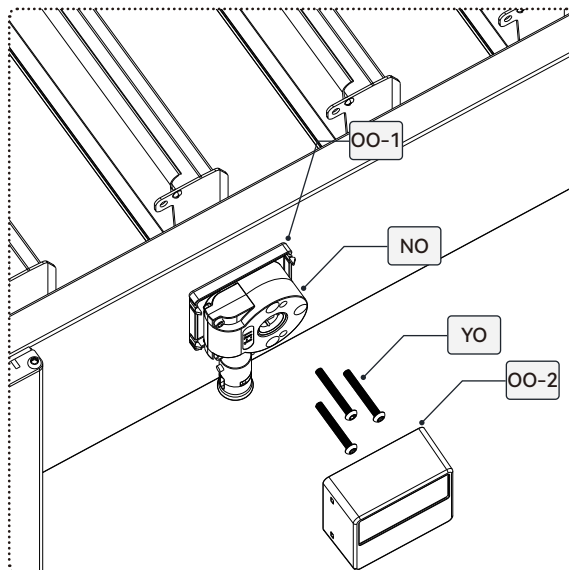
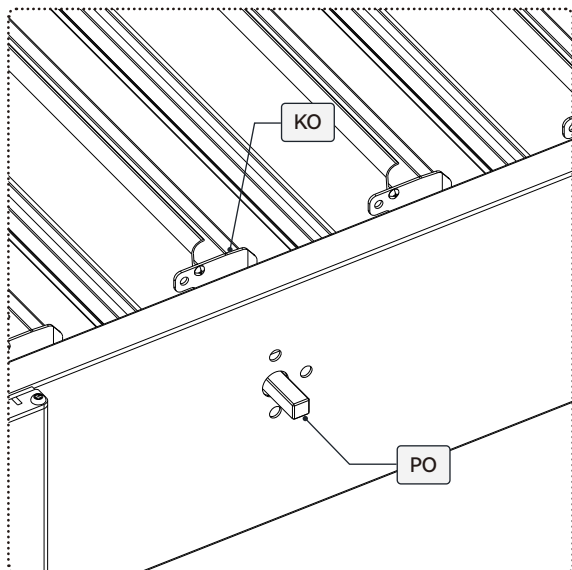
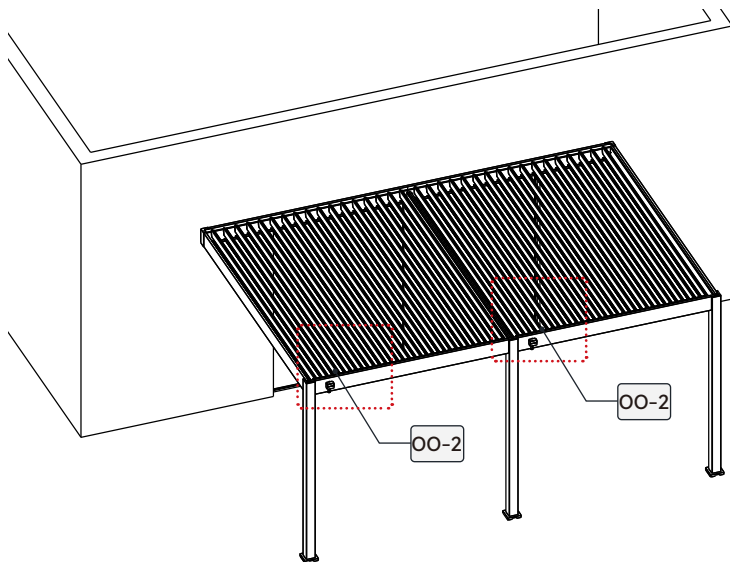

Notice - V1025

FR. Ajouter les barres de connexion à l'avant de la pergola. Attention, la vis X0-2 doit dépasser de 2mm.

EN. Add the connecting bars to the front of the pergola. Please note that screw X0-2 must protrude by 2 mm.

DE. Befestigen Sie die Verbindungsstangen an der Vorderseite der Pergola. Achtung: Die Schraube X0-2 muss 2 mm herausragen.

NL. Bevestig de verbindingsstangen aan de voorkant van de pergola. Let op: schroef X0-2 moet 2 mm uitsteken.

ES. Añada las barras de conexión a la parte delantera de la pérgola. Atención: el tornillo X0-2 debe sobresalir 2 mm.

PT. Adicione as barras de ligação à parte frontal da pérgula. Atenção, o parafuso X0-2 deve sobressair 2 mm.

IT. Aggiungere le barre di collegamento alla parte anteriore del pergolato. Attenzione: la vite X0-2 deve sporgere di 2 mm.

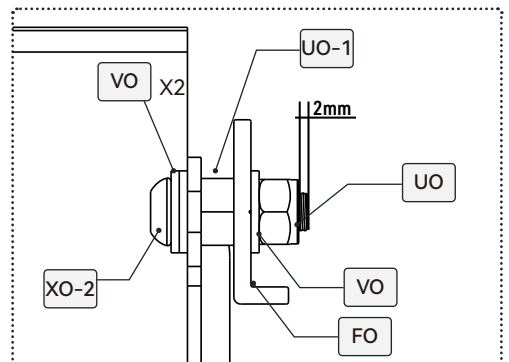
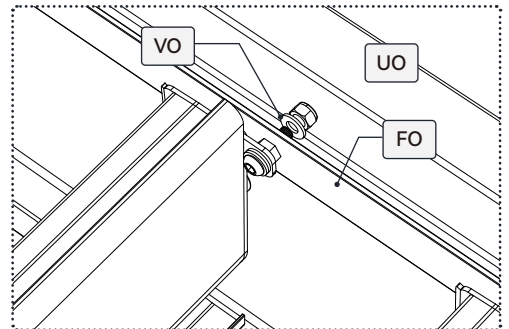
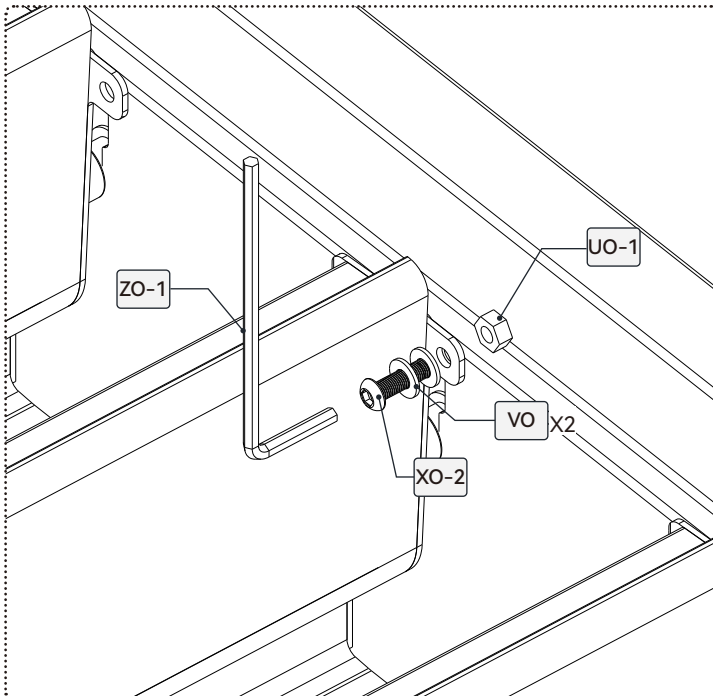
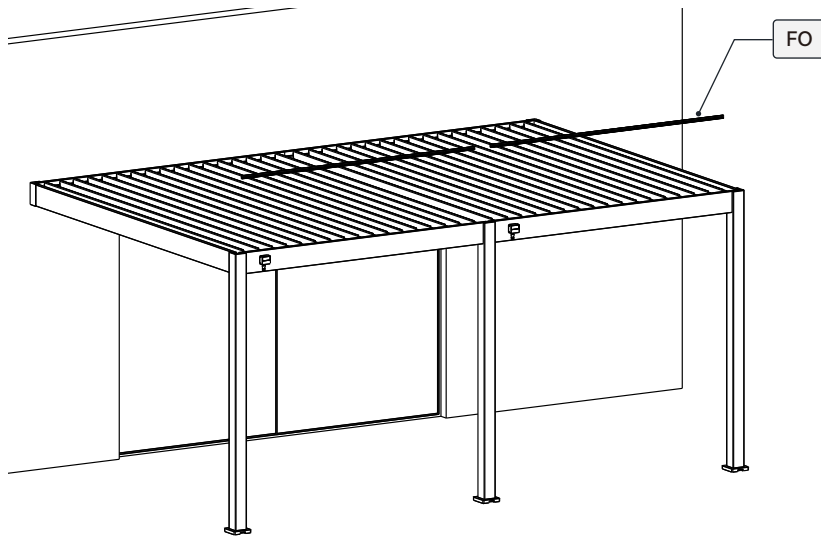
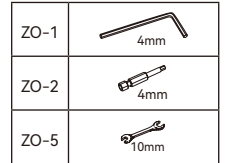
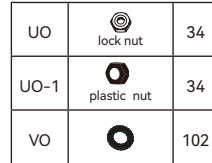
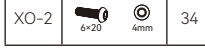

FR. Vérifier le mécanisme d'ouverture et de fermeture de la pergola en utilisant la manivelle. Les lames doivent s'emboîter les unes dans les autres en douceur. Il ne doit y avoir aucun contact, désalignement ou bruit de frottement entre les lames. Ajouter les capuchons de finition au niveau des trous. Un « clic » confirme que le capuchon est correctement installé.

EN. Check the pergola's opening and closing mechanism using the crank handle. The louvers should fit together smoothly. There should be no contact, misalignment, or rubbing noise between the louvers. Add the finishing caps to the holes. A "click" confirms that the cap is correctly installed.

DE. Überprüfen Sie den Öffnungs- und Schließmechanismus der Pergola mit Hilfe der Kurbel. Die Lamellen müssen reibungslos ineinander greifen. Es darf kein Kontakt, keine Fehlausrichtung oder Reibungsgeräusche zwischen den Lamellen geben. Setzen Sie die Abdeckkappen auf die Löcher. Ein „Klicken“ bestätigt, dass die Kappe richtig sitzt.

NL. Controleer het openings- en sluitingsmechanisme van de pergola met behulp van de slinger. De lamellen moeten soepel in elkaar passen. Er mag geen contact, verkeerde uitlijning of wrijvingsgeluid tussen de lamellen zijn. Plaats de afdekkapjes op de gaten. Een 'klik' bevestigt dat het kapje correct is aangebracht.

ES. Compruebe el mecanismo de apertura y cierre de la pérgola utilizando la manivela. Las lamas deben encajar entre sí suavemente. No debe haber ningún contacto, desalineación o ruido de roce entre las lamas. Añada las tapas de acabado en los orificios. Un «clic» confirmará que la tapa está correctamente instalada.

PT. Verifique o mecanismo de abertura e fecho da pérgula utilizando a manivela. As lâminas devem encaixar-se suavemente umas nas outras. Não deve haver qualquer contacto, desalinhamento ou ruído de atrito entre as lâminas. Adicione as tampas de acabamento nos orifícios. Um «clique» confirma que a tampa está corretamente instalada.

IT. Verificare il meccanismo di apertura e chiusura della pergola utilizzando la manovella. Le lamelle devono incastrarsi l'una nell'altra senza difficoltà. Non devono esserci contatti, disallineamenti o rumori di sfregamento tra le lamelle. Aggiungere i tappi di finitura ai fori. Un "clic" conferma che il tappo è installato correttamente.

HO		2	RO		18
----	---	---	----	---	----

